



## The SCADA system applications in management of Yuvacik Dam and Reservoir

Alaeddin Bobat<sup>a,\*</sup>, Tolga Gezgin<sup>b</sup>, Hüseyin Aslan<sup>b</sup>

<sup>a</sup>Vocational School of Arslanbey, Kocaeli University, Arslanbey Campus, Kartepe, Kocaeli 41285, Turkey, Tel. +90 262 3513281; email: bobatus@gmail.com

<sup>b</sup>Akifer Water Services Ltd, Şti., İzmit Water Treatment Plant, No. 231, Başiskele, Kocaeli 41190, Turkey, Tel. +90 532 654 32 94; email: tolga@gezginexpertiz.com (T. Gezgin), Tel. +90 505 883 21 63; email: haslan@akifer.com.tr (H. Aslan)

Received 3 August 2013; Accepted 26 February 2014

---

### ABSTRACT

The industrial control systems, which include supervisory control and data acquisition (SCADA) systems, distributed control systems, and other smaller control system configurations such as skid-mounted programmable logic controllers are often used in the industrial control sectors. The SCADA systems are generally used to control dispersed assets using centralized data acquisition and supervisory control. The SCADA systems are also distributed systems that are used to control geographically dispersed assets, which are often scattered over thousands of square kilometers, where centralized data acquisition and control are critical for system operation. They are commonly used in distribution systems such as water distribution and wastewater collection systems, oil and gas pipelines, electrical power grids, and railway transportation systems. In this article, the SCADA system used in the Yuvacik Dam and Reservoir operation, which is located in Kocaeli province of Turkey is reported and the problems associated with the system operation and their solutions are discussed.

*Keywords:* Water resources; The effective and real time control of water resource; Dam management by SCADA; Problems and solutions

---

### 1. Introduction

As we enter the new millennium, population explosion, increasing worldwide water demands, and rapid climate change are now threatening our fragile environment and the future generation's water supplies as at no other time in known history. Currently, more than one billion people are in lack of accessing sufficient, safe, and healthy water. There is an urgent

need for research and education to focus on the complex and direct link among water supply, usage, management, and the continuing promotion of transference of water management technologies and its infrastructure improvements from developed to developing countries.

Climate change and global warming is the most significant threat to the living beings on our earth in the twenty-first century. In the last 50 years, radical seasonal changes have shown the effects of climate

---

\*Corresponding author.

*Presented at the 1st EWaS-MED International Conference on Improving Efficiency of Water Systems in a Changing Natural and Financial Environment, 11–13 April 2013, Thessaloniki, Greece*

change and global warming in the form of extreme temperatures and weather patterns, which resulted in extremities in weather conditions causing regional droughts and flash floods. Considering ever increasing global population, along with growing urban and industrial areas are taken into account, it is obvious that the global water related problems will be of utmost significance throughout the next decades. Therefore, extensive care should be shown to the operation and management of river basins and dam reservoirs to be able to overcome the water related problems.

Flood and drought are the most important risks during dam management. Simply, the first requirement to operate the dam and reservoir safely against possible risks is that to store enough water according to the operation rule curves (Fig. 1).

But, it is not easy for every time of the year under unexpected changing conditions. The main goal in dam and reservoir operation is to define the strategies that will be able to manage or optimize each risk under continuously changing conditions [1]. The most important factor for the dam operators is to estimate when these risks will occur. Flood, especially, could be managed with the momentary interventions and monitoring since flood is a disaster, which develops too fast (Fig. 2). Therefore, the decision-support systems in dam management are essential, and this is only possible by continuous real time data transfer. At the very moment, supervisory control and data acquisition (SCADA) system comes into play [2].

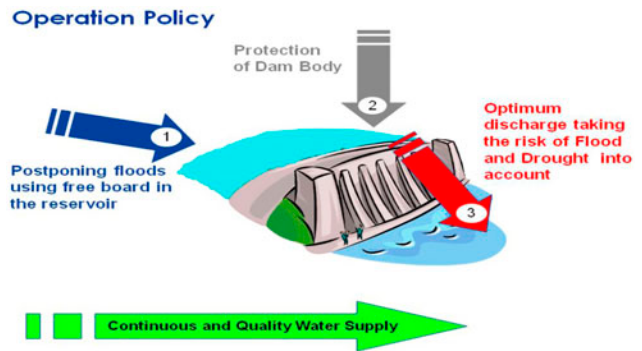

Fig. 2. Dam management policy.

A SCADA system usually consists of a human-machine interface (HMI), remote terminal or telemetry unit (RTU), and programmable logic controller (PLC) [3]. In some cases, PLC system may be not required.

HMI is the apparatus or device which presents process data to a human operator, and through this, the human operator monitors and controls the process. A supervisory computer system intends to acquire data on the process and send the commands to the process. RTU intends to connect to sensors in the process, and convert sensor signals to digital data, then send them to the supervisory system. PLCs are used as field devices because they are more economical, versatile, flexible, and configurable than special-purpose RTU. Communication infrastructure is connecting the supervisory system to the RTU. Besides the

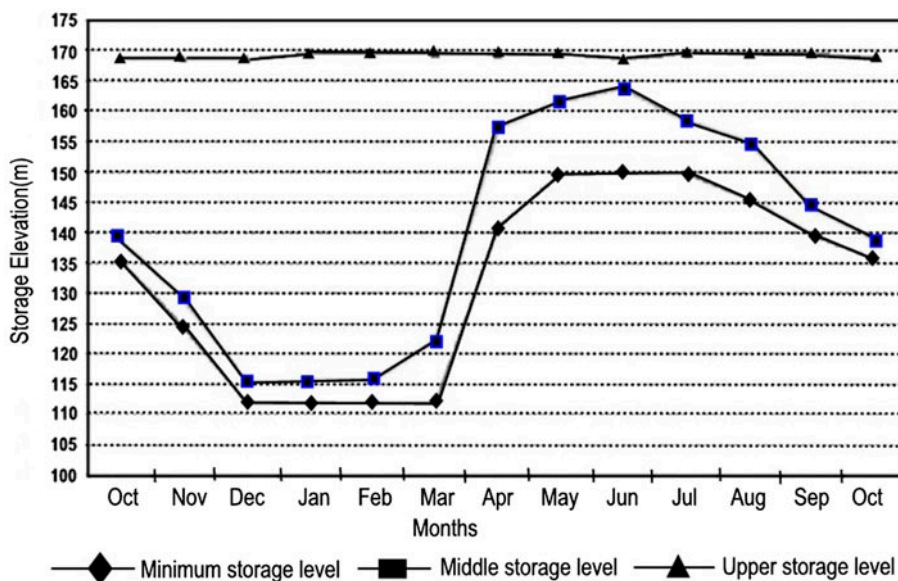

Fig. 1. Operating rule curves.

above, SCADA system includes various process and analytical instrumentation. The term SCADA usually refers to centralized systems which monitor and control entire sites, or complexes of systems spread out over large areas. Most control actions are performed automatically by RTUs or PLCs. Host control functions are usually restricted to basic overriding or supervisory level intervention. For example, a PLC may control the flow of cooling water through part of an industrial process, but the SCADA system may allow operators to change the set points for the flow, and enable alarm conditions, such as loss of flow and high temperature, to be displayed and recorded. The feedback control loop passes through the RTU or PLC, while the SCADA system monitors the overall performance of the loop [4,5].

Data acquisition begins at the RTU or PLC level and includes meter readings and equipment status reporting to SCADA as required. Data is then compiled and formatted in such a way that a control room operator, using the HMI, can make supervisory decisions to adjust or override normal RTU (PLC) controls. Data may also be fed to an historian, often built on a commodity Database Management System, to allow trending and other analytical auditing [6]. SCADA systems are the important systems used in national infrastructures such as electric networks and water supply systems. However, SCADA systems have many security vulnerabilities [7].

The purpose of this article is to explain the use of SCADA system during dam management, how to

overcome the operational difficulties, and finding alternative solutions in water resources planning and management.

## 2. Yuvacik Dam and Reservoir

Kocaeli is one of the biggest industrial cities located in eastern Marmara Region of Turkey. The domestic and industrial water of Kocaeli is supplied by Yuvacik Dam, the largest privately financed Build–Operate–Transfer water project in the world at the same time. The project went into commercial operation on 18 January 1999, three months ahead of schedule and within construction cost under the operational management of Thames Water O&M Contractor [8]. Later on, the operation of dam, water treatment plant (WTP), pipeline and pumping stations was acquired by Akifer Water Services in 2009. The basin is between 40°30′ to 40°41′ northern latitudes and 29°48′ to 30°08′ eastern longitudes (Fig. 3).

The basin is surrounded by the following settlements: Izmit and Golcuk towns in the north; Haciosman village and Iznik town in the southwest; and Pamukova in the southeast and Kartepe (a famous ski center) in the northeast.

Yuvacik Basin is a south to north oriented basin; streams originate from the southern parts of the basin and join together in the reservoir lake in the north of the basin. The reservoir lake is about 12 km away from Kocaeli City center.



Fig. 3. Yuvacik Dam and Reservoir in Izmit-Kocaeli of Turkey.

The domestic and industrial water requirement was projected as 142 Mm<sup>3</sup>/y and the regulation rate is 77.1%. The total reservoir volume at the top water level of 169.68 m ASL is 51.13 Mm<sup>3</sup> and dead volume of reservoir 5 Mm<sup>3</sup> [9]. The surface area of the reservoir at the top water level of 169.68 m ASL is 1.75 km<sup>2</sup>. The catchment area is 258 km<sup>2</sup> and peak discharge of catastrophic flood 1,593 m<sup>3</sup>/s, and dead volume of reservoir 5 Mm<sup>3</sup>. The catchment area is 258 km<sup>2</sup> and peak discharge of catastrophic flood 1,593 m<sup>3</sup>/s [10].

It is expected that the reservoir volume will gradually reduce over time as a result of siltation. Inflows to

the reservoir can be monitored with the trapezoidal concrete flumes built at the three main rivers (Kirazdere, Kazandere, and Serindere) and the overflow measuring gage mounted in the break pressure tank of ISU (Kocaeli Water and Sewerage Administration General Directorate) at the left bank of the reservoir.

### 3. SCADA system in dam monitoring

SCADA system in dam management is used (i) to enable effective and real-time control of the water resource, (ii) to give early warning of atmospheric

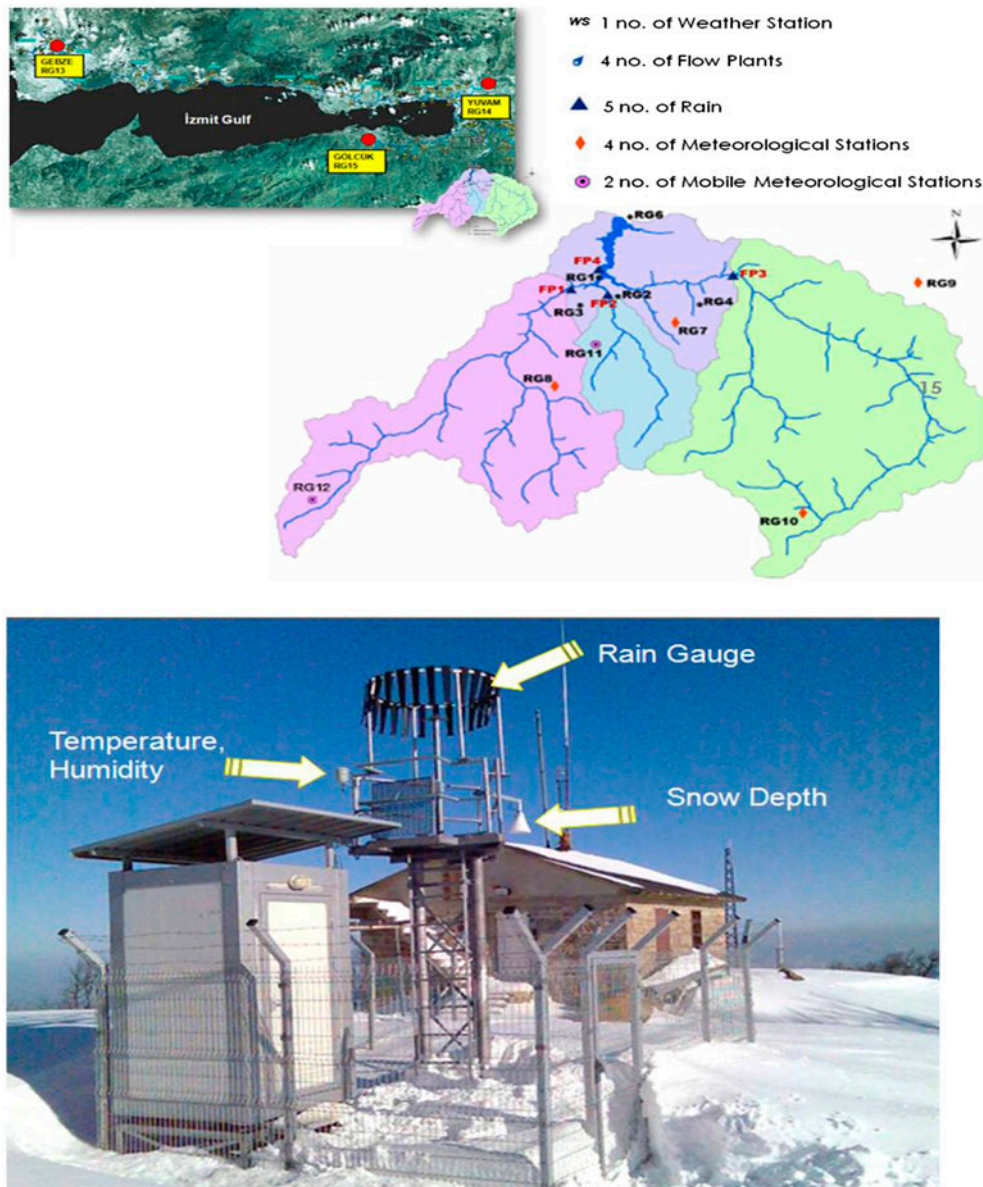

Fig. 4. The locations of monitoring devices and meteorological station.

conditions in the catchment area, (iii) to predict the impact of inflows on the reservoir volume, (iv) to allow timely control of spillway operation, (v) to alert the operator of any sudden change in toe-drain flow, and (vi) to provide historical data records for improved resource management.

For these reasons, there have been four flow measurement stations, five rainfall stations, four fixed meteorological observation stations, two mobile meteorological observation stations, three reservoir level measurement stations, one toe-drain flow measurement station, and one automatic air station (the velocity and direction of wind, evaporation, temperature, moisture and radiation) in the catchment area (Fig. 4).

At all those flow measuring sites, there is an ultrasonic level gage mounted 1.5 m above the base of the trapezoidal concrete flume that transmits the level values to the dam management SCADA system. This data is converted to flow.

### 3.1. Main monitoring and measurement

Three SCADA computers, at the spillway guard house, control room, and dam operation house, are settled to monitor all the data and to manage the case during emergency. All instant flows, total flows, meteorological observations, etc. at all the measuring systems can be monitored electronically and recorded at the PC stations. Moreover, authorized staffs can reach all the data at every location from their own PC's. All raw data recorded inside the SCADA are processed daily by dam operation supervisor and the summary of the data is recorded on an excel spreadsheet [11].

Reservoir and spillway levels and outlet flow monitoring are obtained from a variety of instruments used including: (a) pressure transducer for reservoir level, (b) ultrasonic level measurement for spillway level, (c) digital encoder for spillway gate opening, (d) electromagnetic flow meters (FM) for raw water and compensation flows, and (e) ultrasonic level and v-notch weir for toe drain flow.

Reservoir level measurement is achieved using a conventional submerged pressure transducer (Type: Druck PTX 1830) installed at a nominal 110 m (ASL) level on the slope of the off-take gate structure. It is threaded inside a plastic conduit for protection and ease of maintenance.

The measurement of the spillway level is achieved in the approach channel to the spillway, utilizing a 10 m range ultrasonic level sensor with a zero point of 159.95 m ASL. This level is used in conjunction with each of the spillway gate opening measurements to compute flow over the spillway. For this reason, it is

necessary for the level measurement point to be taken at least 20 m far from the spillway gates in order to avoid "drawdown" of the fluid level resulting in high flows under the spillway gates. Ultrasonic level measurement is affected by temperature. Therefore, sensors are temperature compensated. However, direct sunlight onto the level sensor will give rise to errors by raising the sensor temperature above ambient. For this reason, the sensor is shielded by an insulated stainless steel hood.

The measurement of the spillway gate positions is performed by a digital encoder driven from the input shaft to the existing gate opening indicator mechanisms. The digital output of the multi-turn encoder is conditioned and converted to a 4–20 mA output signal for transmission to a local PLC. These digital encoding devices are extremely accurate, but due to the nature of the gates used for controlling spillway flow, setting of the gate zero point is very important. The gate zero should coincide with the point at which leakage begins to appear under the gate, indicating decompression of the bottom seal. Full compression of this seal can make a zero-point difference of up to 5 cm, which would be reflected in an apparent increase in computed flow.

The outlet flows from the reservoir comprise of (a) raw water flow to the WTP, (b) compensation flow to the river, (c) spillway discharge flow, (d) howell bunker valve flow, (e) toe-drain flow, and (f) evaporation. Of these flows, the raw water and compensation flows are measured using ABB Kent-Taylor full bore electromagnetic FM (similar to those used throughout the project). The spillway discharge flow is computed from the spillway level and spillway gate opening measurements. The howell-bunger valve flow is computed from an operator input of the valve position and from the reservoir level measurement. The toe-drain flow is measured using a pair of 60° V-Notch weirs in conjunction with ultrasonic level measurements on each side of the toe-drain shaft. Finally, evaporation is a calculated value based upon the data downloaded from the weather station.

### 3.2. System communication

Outstation communications are obtained from 10 outstations which transmit data back to the master telemetry unit using radio waves. Rain gages (RG), FM, and stable/mobile stations are installed on different locations of the catchment area and in the near regions of dam and reservoir (Fig. 4). RG13-14-15 installed at three locations outside catchment area in order to serve as early warning system.

Radio frequency (RF) and general packet radio service (GPRS) are used as the communication method, since locations are quite far from each other and also from the control room. In 2003, RTU stations installed on the nine locations are communicated by means of RF at the beginning. Each outstation is equipped with a “Versanet” radio transmitter/receiver manufactured by RDT Ltd as RTU. All the stations carry out real-time communication with the center station located in the spillway guardhouse, control room, and dam operation house via radio modem in RTU stations and provide data for the dam management system (DMS)-SCADA at 5 min intervals [2,11].

Later on, new RTUs—four fixed, two mobile, and three RG—had been further installed at nine locations to obtain more detailed data. In those stations, GPRS is used as communication system. Temperature, humidity, rainfall, and snow level are measured from fixed stations. System works with sun panels as energy source. In stations where previously four rainfall stations existed, CR1000 data logger and control module of Campbell Scientific are used.

Versanet radio systems are termed as “low power” radios, which permit transmission power up to 500 mW. All outstations are battery supported and the radio system in all, but RG2 is configured for “low power operating mode.” In this mode, the outstation radios are normally “asleep” and “wake up” to transmit on a timed interval of 5 min. RG2 acts as a repeater station for a number of other outstations, which are unable to communicate directly with the master telemetry station.

Some of the RTUs are located at about 1,500 m ASL since Yuvacik catchment is geographically very hilly. It is not possible to reach these RTUs for maintenance or repairing, especially under hard winter conditions. So availability and stability of the

communication system are very important. All critical locations have redundant communication, i.e. the locations used GPRS system, redundant communication module, and redundant GSM operator (Turkcell and Vodafone). Also, RF and GPRS systems are used at FM stations simultaneously. If the master protocol/operator fails, the communication will continue automatically via a redundant system (Fig. 5).

### 3.3. Rainfall and flow measurement instruments

The rainfall monitoring is achieved using the tipping bucket type RG manufactured by Environmental Measurements Ltd. Each RG is aerodynamically profiled to minimize the effect of air turbulence on the rainfall measurement. Rainfall is collected by the 254 mm diameter funnel and directed to an internal tipping bucket system designed to tip every time a specific volume of water is collected. This volume of 10.13 ml is the equivalent to rainfall of 0.20 mm over the area of the funnel. The tipping bucket is shown tilted to the left, beneath the RG funnel. In this position, rainwater collected by the funnel is, thus, directed into the right hand compartment of the tipping bucket, causing it to tilt to the right when the correct volume has been collected. As it does so, a magnetic arm attached to the tipping bucket sweeps past a reed switch in the center upright. This produces a contact closure in the reed switch, lasting a few milliseconds. It is this pulse output that is used to represent an equivalent of 0.2 mm of rain.

There are a number of guidelines to be followed when placing RG to ensure that the instruments are able to accurately measure rainfall. Ideally, RG should be placed at ground level, in an area of low-lying natural vegetation, away from any buildings, structures and trees, which may disturb the airflow. However, it

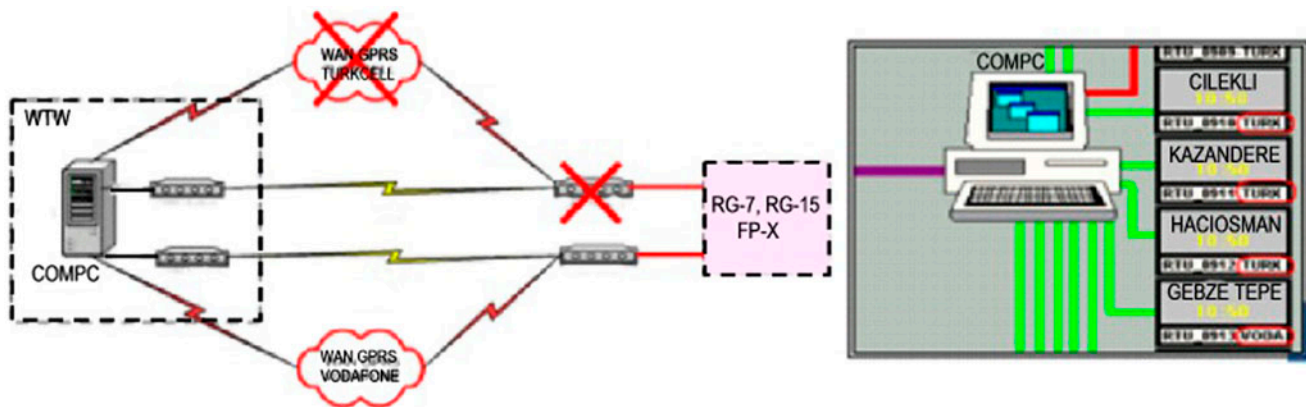

Fig. 5. Online redundant GPRS system.

is also important that they are not subject to interference by either human or animal activity. For security reasons, our project RG were placed on top of mosques, ISU (local water authority), and project buildings which, while not ideal in terms of measurement techniques, are proven to be satisfactory in terms of a consistent result across the catchment.

Inlet flow monitoring is achieved using open channel FMs manufactured by MMI-Europe Ltd. Each Model 253 flow monitoring system comprises of a flow sensor and a flow transmitter unit designed to measure flows in open channels or streams (Fig. 6).

The system computes flow by measuring both the depth and the velocity of the stream at the sensor location. It uses a calibrated look-up table of the gaging station profile to obtain the stream cross-sectional area ( $A$ ). It makes an adjustment to the measured velocity (based upon site calibration data) to produce an average velocity for the stream cross section ( $V$ ).

Finally, flow is calculated using the formula

$$Q = V \times A \quad (1)$$

where  $Q$  = flow,  $V$  = velocity, and  $A$  = area.

The FM sensor is encapsulated in a polyurethane housing to protect the sensor electronics. Velocity is sensed via three pyramid-shaped electrodes mounted on the top of the sensor body, which generate an electromagnetic field at  $90^\circ$  to the direction of the flow. The fluid cuts this electromagnetic field producing an electrical signal, which is directly proportional to the fluid velocity. This velocity is displayed at the transmitter in m/s. Level sensing is achieved by a temperature compensated piezo-resistive pressure transducer mounted in a ported compartment on the underside

of the housing. The top-side of this transducer is referenced to atmosphere via a tube in the sensor cable. The signal produced by this transducer is amplified and conditioned in the transmitter to give a displayed value in millimeters.

### 3.4. Connection and screen system

Data collection platforms collect data from sensors at each site and transmit values via satellite and radio. These data are received by central servers and are stored in relational database management systems. In-touch software of Wonderware firm is used as SCADA system. Hydrologic database software with a graphical user interface is used to access the data. The interconnection of SCADA computers realizes with TCP/IP protocol by means of digital subscriber line (DSL) pipe and asymmetric digital subscriber line (ADSL) from a point to another. In DSL method, the laid cable is used among locations. ADSL connection is also supplied by an Internet server firm. SCADA computer system provides this information to decision makers in real-time through a combination of radio and satellite telemetry, microwave, fiber optic, and Internet technology. The system incorporates redundancy to maximize data availability under a wide range of hydrological and meteorological conditions. Through the use of this system, the dams can be operated more safely and emergency plans can be more effectively coordinated and implemented with the emergency management agencies (Fig. 7).

## 4. Dam management system

DMS shortly is a decision support system providing basic opportunity to explore alternative management scenarios in water resources planning and management. DMS is based on precipitation-runoff modeling studies (infiltration loss and base-flow parameters of each sub-basin) including SCADA system. Precipitation-runoff models have been widely used through the last century to formulate a reliable relationship between the precipitation (input of the model) and runoff (output of the model). The most important models (HEC-HMS and HEC-RESSIM) are developed by the US Army Corps of Engineers Hydrologic Engineering Center. It includes many of well-known and well applicable hydrologic methods to be used to simulate rainfall-runoff processes in river basins [12].

Meteorological data required for Yuvacik Dam and Reservoir are obtained by DSI (State Hydraulic Works) and DMI (State Meteorology Works) and Meteorological Stations in Yuvacik Watershed.



Fig. 6. Flow plant on the running waters.

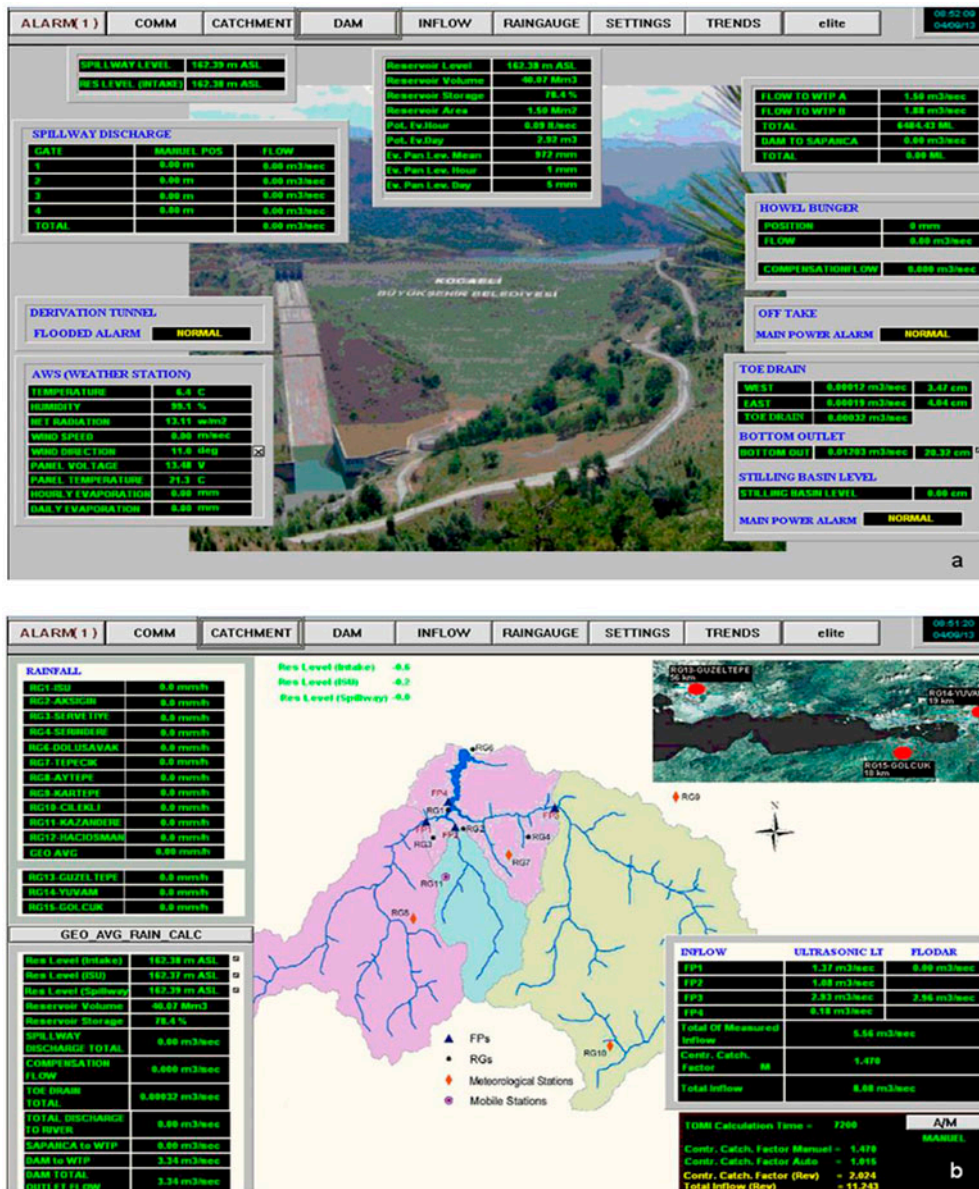

Fig. 7. SCADA pages on the screen (a) dam and (b) catchment area.

#### 4.1. HEC-HMS (Hydraulic modeling system)

Hydraulic modeling system (HEC-HMS) is designed for surface water hydrology simulation. Basically, it includes all of the different components of the hydrologic cycle for representing precipitation, evaporation, and snowmelt at atmospheric conditions over a watershed. It also involves infiltration, surface runoff, and base-flow over the land surface. It includes stream flow with possible percolation losses below the channel.

The program can be adapted to fit almost any watershed; it is not limited to just one custom watershed or a certain class of watersheds. For each

component of the hydrologic cycle, it provides multiple choices. Some of those choices are better suited to different types of watersheds. The job of the user is to select the best choices for their watershed, and then enter the appropriate parameter values. The values will be things like areas, river lengths, soil properties, etc. These parameters adapt the model to represent a particular watershed. The program does the hard part of matching all the selections by the user together into a single, comprehensive model of the watershed. It also does the tedious work of solving the differential equations behind each selection in order to compute



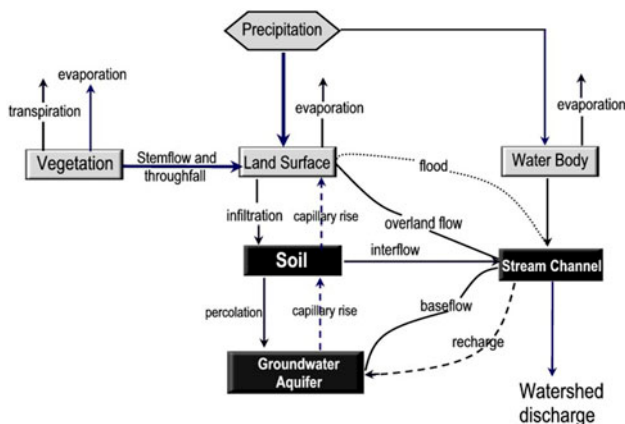

Fig. 8. Hydraulic modeling.

results. It then provides analysis tools, such as statistical summaries to better understand the results (Fig. 8).

All of the capabilities of the program are controlled by a nice graphical interface that is easy to use. The watershed is represented with a map that shows all of the modeling components plus background maps for spatial orientation. Clicking on any item in the program immediately shows the parameter data for it so it can be edited. Plenty of graphs and tables are provided for visualizing results in helpful ways [13].

#### 4.2. Hec-ResSim (Reservoir simulation system)

Hec-ResSim is an original rule-based approach model to mimic the actual decision-making process that reservoir operators must use to meet operating requirements for flood control, water supply, and environmental quality. Parameters that may influence flow requirements at a reservoir include time of year, hydrologic conditions, water temperature, and simultaneous operations by other reservoirs in a system. The reservoirs designated to meet the flow requirements may have multiple and/or conflicted constraints on their operation. Hec-ResSim describes these flow requirements and constraints for the operating zones of a reservoir using a separate set of prioritized rules for each zone. Basic reservoir operating goals are defined by flexible at-site and downstream control functions and multi-reservoir system constraints. As Hec-ResSim has evolved, advanced features such as outlet prioritization, scripted state variables, and conditional logic have made it possible to model more complex systems and operational requirements [14]. The graphical user interface makes Hec-ResSim easy to use and the customizable plotting and reporting tools facilitate output analysis (Fig. 9).

Hec-ResSim is one such reservoir simulation model. Engineers and planners use it for predicting the behavior of reservoir systems in water management studies, and helping reservoir operators to plan releases in real time during day-to-day and emergency operations.

Input (precipitation) and output (runoff) of Yuvacik Dam and Reservoir is simulated by this model and these data obtained are displayed graphically and numerically on the screen in the control room.

#### 5. Operational difficulties

The most difficult problem in the management of small reservoirs is to keep the reservoir under control against risks such as flood and drought. The Yuvacik Dam and Reservoir is an industrial complex, and its management is difficult since the capacity is small (51.13 Mm<sup>3</sup>), annual average inflow of last 15 years is low (184.20 Mm<sup>3</sup>), annual demand of the water is high (142 Mm<sup>3</sup>), and spillway capacity is about 1,560 m<sup>3</sup>/s, which is nearly 16 times higher than the discharge channel capacity, 100 m<sup>3</sup>/s. Consequently, Yuvacik Reservoir, which is a small dam, has to be operated with very carefully planned risk and crisis management (Fig. 10). Therefore, it is sensible to some difficulties resulting from management and operational, and maintenance system.

For some installations, the cost resulting from control system failure can be extremely high. When comparing the advantages and minimized risks, the installation cost of these systems is negligible. Hardware for some SCADA systems is strong to withstand extreme climate conditions, vibration, and voltage extremes. In most critical installations, reliability is enhanced by having redundant hardware and communications channels, up to the point of having multiple fully equipped control centers. A failing part can be quickly identified and its functionality will automatically be taken over by backup hardware. A failed part can often be replaced without interrupting the process.

Especially, some equipment may be effected by cold weather conditions if power cannot be supplied even for a short period of time. For example, since some parts of the RTU in Yuvacik Basin are located above 1,000 m ASL, they freeze (Fig. 11) and such critical locations have redundant communication module and GSM operators. When the master protocol/operator fails, the communication continues via redundant system automatically. Therefore, electrical heater can be used as a precaution.

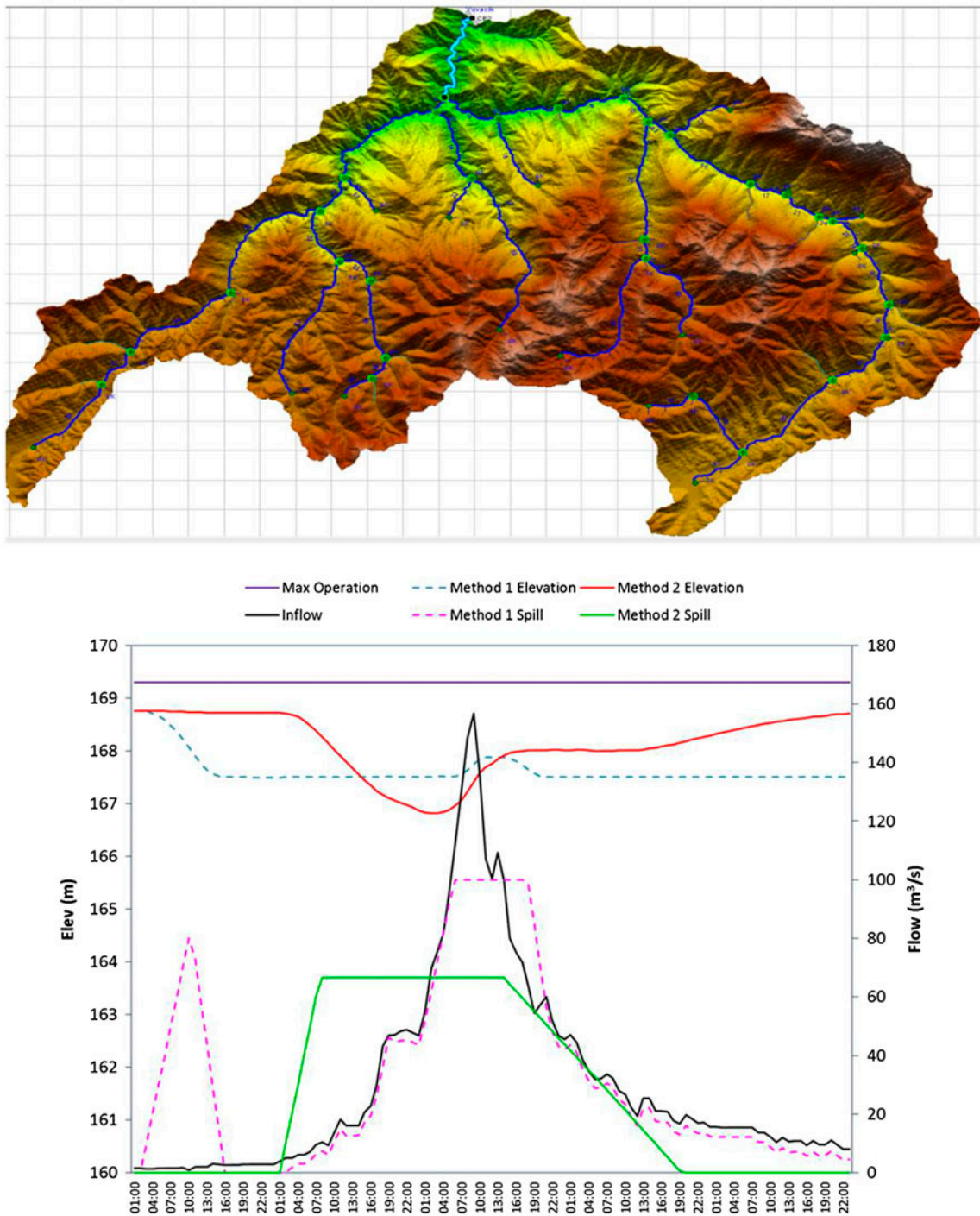

Fig. 9. Display of Hec-ResSim model on the screen.

The security of a SCADA system is important as these systems are open to vandalism. Although SCADA systems are designed to be open, robust, easily operated, and repaired, they are vulnerable to some types of network attacks. There are many threat

vectors to a modern SCADA system. One is the threat of unauthorized access to the control software, whether it is human access or changes induced intentionally or accidentally by virus infections and other software threats residing on the control host

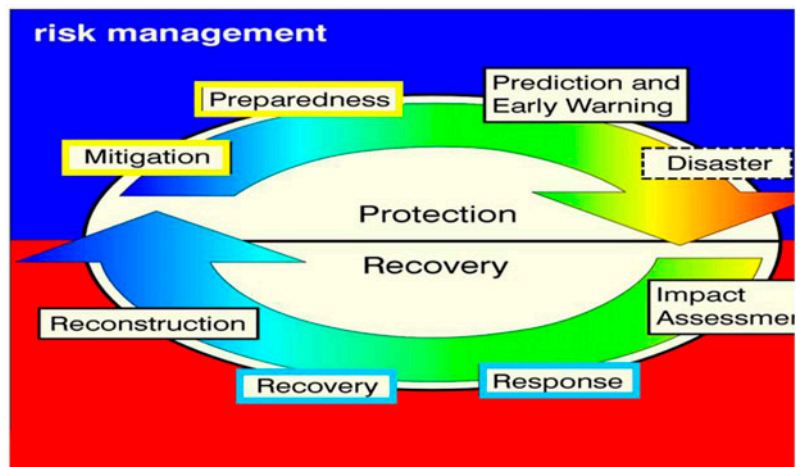

Fig. 10. Modern disaster management system in the reservoirs.



Fig. 11. The some parts of frozen equipment.

machine. Another is the threat of packet access to the network segments hosting SCADA devices. In many cases, the control protocol lacks any form of cryptographic security, allowing an attacker to control a SCADA device by sending commands over a network. In particular, security researchers are concerned about (i) the lack of concern about security and authentication in the design, deployment and operation of some existing SCADA networks, (ii) the belief that SCADA systems have the benefit of security through obscurity through the use of specialized protocols and proprietary interfaces, (iii) the belief that SCADA networks are secure because they are physically secured, and (iv) the belief that SCADA networks are secure because they are disconnected from the Internet [15,16].

## 6. Conclusion and suggestions

As the world's water resources become increasingly stressed, effective tools for management become more

important. One tool often used in water resources management is decision support systems. Bringing solutions to meteorological and hydrological problems, by setting up and using decision support systems can only be available with the help of SCADA systems.

DMS, basically, is a decision support system, providing basic opportunity to explore alternative management scenarios in water resources planning and management.

The purpose of recorded data by SCADA together with DMS makes operation studies available for reservoirs; whether the planned reservoir volume is of sufficient size, economically worth, amount of water released depending on the relationship between water users and time periods, and the amount of water to be held or released in accordance with filling and emptying time periods of reservoirs. In other words, the data recorded by the system constitute the most important steps of operational success.

The reservoir operation of Yuvacik Dam is very crucial, especially for the periods of flooding and

drought due to multi-purpose characteristics of the dam that is built to meet the need for drinking water of Kocaeli City, despite the relatively small capacity of its reservoir. The drainage discharge conditions set for the downstream of the reservoir as well as the upstream conditions also require improvements in reservoir operation conditions. In addition, increasing needs of the settled industry within the region by time will cause an increase in the water demand. SCADA system also plays an important role for future improvement studies with the help of inflow predictions for Yuvacik Dam/Reservoir and control of reservoir operation strategies by holistic approach of hydrologic and hydraulic model simulations. Improvements done for the operation studies of the reservoir, which is in operation since the year 1999 as well as including the forecasts of inflows to the reservoir, affect the managerial decisions positively.

Owing to a healthy and well-maintained DMS, operators can analyze the risks well and make the decisions timely and accurately. At the same time, the operator of Yuvacik Dam and Reservoir can predict the hydrological and meteorological anomalies and so, the required measures can be taken. In this manner, the dam and reservoir could be operated with the optimal utility.

DMS, developed for Yuvacik Dam Operation, specially, is a result of the expert teamwork. But, the survival of this system is dependent on the maintenance, repair, and calibration of instruments used. In order to develop SCADA systems, it is necessary to establish a robust cooperation between public and private sectors as well as universities.

## References

- [1] A. Bobat, T. Gezgin, Kocaeli drought plan in management of Yuvacik reservoir, Second Annual YÖK-SUNY Collaboration Symposium Scientific Collaboration for Sustainable Development, May 23–25, Çukurova University, Adana, Turkey, 2007, pp. 76–90.
- [2] H. Aslan, T. Akgün, Baraj Yönetim SCADA Sistemi (Dam Management SCADA System), Bileşim Otomasyon Dergisi, (September 2010), 8–13.
- [3] K. Stouffer, J. Falco, K. Kent, Guide to Supervisory Control and Data Acquisition (SCADA) and Industrial Control Systems Security, National Institute of Standards and Technology (NIST), Special Publication 800-82, 2006.
- [4] K. Barnes, B. Johnson, R. Nickelson, Review of Supervisory Control and Data Acquisition (SCADA) Systems, Prepared for the U.S. Department of Energy Under DOE Idaho Operations Office Contract DE-AC07-99ID13727, 2004.
- [5] T. Wilson, PLC Based Substation Automation and SCADA Systems and Selecting a Control System Integrator, Workshop, Las Vegas, NV, 1999.
- [6] V. Rajeswari, Y. Rajeshwari, L.P. Suresh, Real-time implementation of hydroelectric power plant using PLC and SCADA, Int. J. Eng. Res. Appl. 2 (2012) 899–902.
- [7] R.L. Krutz, Securing SCADA Systems, Wiley, Indianapolis, IN, 2006.
- [8] M. Newton, Renovation of a steel water pipeline after Izmit earthquake, Hydropower Dam 9 (2002) 76–79.
- [9] M. Zengin, A. Hizal, A. Karakaş, Y. Serengil, D. Tuğrul, M. Ercan, Planning of the Renewable Natural Resources of the Izmit-Yuvacık Watershed for Water Production in Terms of Quality, Amount and Regime, Poplar and Fast Growing Forest Trees Research Ins., Izmit, Publ. No. 244, 2005.
- [10] A. Bobat, T. Kutlu, A. Çelik, M. Unal, A. Otari, Water supply crisis in the Eastern Marmara Region of Turkey, First International Conference on Environmental Management, Engineering, Planning and Economics (CEMEPE), Proceedings, vol. II, June 24–28, 2007, Skiathos Island, pp. 1074–1080.
- [11] Thames Water SCADA System, Thames Water Seminars, Izmit, 2007.
- [12] USACE-HEC. Hydrologic Modeling System, HEC-HMS v3.0.1. User's Manual, 2006.
- [13] M.K. Yener, A.A. Şorman, A. Şensoy, T. Gezgin, Modeling studies with Hec-Hms and runoff scenarios in Yuvacık basin, Türkiye, International Congress of River Basin Management, Antalya-Turkey, March 22–24, 2007, pp. 621–634.
- [14] J.D. Klipsch, T.A. Evans, Reservoir operations modeling with Hec-ResSim, Proceedings of the Third Federal Interagency Hydrologic Modeling Conference (3rd FIHMC), Reno, NV, April 2–6, 2006, pp. 1–8.
- [15] B. Reaves, T. Morris, Analysis and mitigation of vulnerabilities in short-range wireless communications for industrial control systems, Int. J. Crit. Infrastruct. Prot. 5 (2012) 154–174.
- [16] A. Hildick-Smith, Security for Critical Infrastructure SCADA System, SANS Institute, Swansea, 2005.