



Synthetic reactive dye wastewater treatment by using nano-membrane filtration

H. Reza Rashidi, N. Meriam Nik Sulaiman*, N. Awanis Hashim,
C. Rosmani Che Hassan, M. Redzuan Ramli

Department of Chemical Engineering, Faculty of Engineering, University of Malaya, 50603 Kuala Lumpur, Malaysia, Tel. +60 12 2105130; Fax: +60 3 7967 5319; email: meriam@um.edu.my

Received 18 September 2013; Accepted 3 April 2014

ABSTRACT

The batik industry is considered to be one of the largest textile cottage industries in the Southeast Asian region. Batik processing utilizes wax as a physical resistant and consumes a large amount of water during dyeing, fixing, and washing process; thus, generating harmful wastewater including dye, wax, and other auxiliaries. Respectively, an efficient wastewater treatment method is deemed necessary to meet legal emission standards. In this study, application of polyamide nano-membrane to remove dyes was evaluated for five different fiber reactive dyes' wastewater, namely reactive blue 15, reactive red 194, reactive yellow 145, reactive black 5, and reactive orange 16. The discussed dyes were tested in low concentration (16 mg/l) during a 60 min filtration process. The efficiency of filtration was calculated based on pre-process and post-process analytical experiments. The flux for all the samples ranged between 7.8 and 9.2 ml/cm²s. The permeate pH value of the samples was observed to slightly increase, within a range of 6.4–7.1. Conductivity measurements for the samples indicated dramatic reduction for each sample dye solution compared to the sample from the feed to permeate during the filtration runs. Chemical oxygen demand value in the permeate samples was reduced to zero, representing a dye removal efficiency of more than 90%, thus successfully meeting the environmental legal standard.

Keywords: Nano-membrane filtration; Batik industry; Wastewater treatment; Reactive dye

1. Introduction

It is a well-known fact that textile industries require significant amount of water [1]. The process generates large volume of wastewater containing harmful chemicals (dyes and auxiliaries) to the environment if discharged untreated [2,3]. Batik as the largest cottage industry plays an important role in the cultural value of the local families while being a major

source of their income. It is also directly ingrained into the livelihood of families who live in the Southeast Asian region specifically Malaysia and Indonesia [4]. Batik factories generate a large amount of wastewater that includes wax, resin, sodium silicate, and dyes similar to other textile processes. Unfortunately, many traditional textile industries, including the local batik factories, discharge their wastewater into the environment without appropriate treatments [4–6]. Presence of dyes is one of the main concerns of the wastewater from batik factories. The most commonly used dyes in

*Corresponding author.

all textile industries are fiber reactive dyes [2,6–8]. Generally, during this dyeing process, the amount of water and reactive dyes per kilogram of cloth ranges between 70 and 150 l, and 30 and 60 g, respectively [9,10]. Commonly 10–50% of the used reactive dyes exist as unfixed dyes in wastewater [11]. However, the amount of dye usage in the batik industries follows the range of 10–20% of conventional dyeing techniques, since brush dyeing is applied. Remazol and Procion MX reactive dyes are popular choices in this particular industry due to their specific physical and chemical properties [7,12].

Primary pre-treatment is capable of removing wax, resins, and other auxiliaries [13]; however, treating the reactive dyes' wastewater remains to be a significant issue in batik industry. Due to the aforementioned facts [14,15], early conventional wastewater treatment techniques, such as Fenton reagent [16,17], ozonation [18], photochemicals [19], electrochemicals destruction [20], activated carbon [21,22], oxidation [23], ion exchange [17,24], and membrane, were utilized for the treatment process [3,6]. Among all conventional treatment methods, the membrane process is considered to be the most appropriate water and wastewater treatment method [12,14]. Moreover, simplicity of usage for membrane plus ease of replacement and cartridge properties during the treatment cycle can play a significant role for membrane application in water and wastewater treatment industries [14,23,25].

Among all types of applicable membrane filters [14,26], the nano-filtration (NF) is widely applied and used in textile industry processing specifically for the treatment of wastewater from the dyeing process due to the pore sizes, high efficiency, low process cost, and user-friendliness [27–33]. Riera-Torres et al. [34] reported that the combination of membrane filtration with coagulation–flocculation treatments showed an efficiency of almost 100% dye removal in different studies of reactive dyes' solutions. Aouni et al. [35] investigated the application of NF and ultra filtration (UF) in textile wastewater treatment in terms of parameters retention such as conductivity, Chemical oxygen demand (COD), and color rejection. High COD and conductivity removal rate (>80% and >90%) was found by UF and NF treatment, respectively. The reactive dyes' color rejection was obtained at the rate of more than 90% by NF membrane filtration treatment. Sun et al. [36] applied a self-prepared thin-film composite NF membrane via interfacial polymerization on a dual-layer hollow fiber membrane surface during the dye removal of textile wastewater. Their findings indicate greater rejection rate (>99%) due to physical and chemical properties of membrane surface while encountering positive and negative groups of

reactive dyes. Application of NF with micro-filtration (MF) pre-treatment stages showed the average values of 100, 60, and 35% for color rejection, COD, and salinity removal, respectively, for textile wastewater treatment [1]. Petrinić et al. [27] applied NF for treating textile printing wastewater containing reactive dyes. They observed high dye retention rates for all tested dyes' samples (>99.4%) plus the organic substances removal rate ranging between 20 and 50%. Application of hybrid membrane treatment techniques (MF/NF) in selected textile reactive dyeing bath effluent in different textile industries was reported by Tahri et al. [37]. The results indicated almost 99% removal percentage of colors plus 0.2 NTU of turbidity value. Avlonitis et al. [38] used NF membrane treatment techniques for simulated cotton wastewater treatment. Their results indicated complete de-colorization and feed effluent salt rejection.

Correspondingly, fouling is the major common problem in all types of NF membranes. Generally, fouling decreases the membrane flux during the separation processes either on the surface of a membrane or within its pores [39]. Among these factors, colloidal fouling due to colloid formation on membrane surface by effluent contaminants, such as dyes and silica, is the main critical issue during NF membrane application for textile dyeing wastewater treatments [40]. However, polyamide components are mostly applied in nano-membrane fabrications due to their chemical and physical properties such as higher thermal stability and excellent mechanical properties [41]. Consequently, they attract reactive dye groups on the membrane surface. This property not only performs as the most efficient dye removal but also can increase fouling during the separation process. Accordingly, the NF membrane has been chosen in this study to investigate the application of accessible commercial nano-membrane in low concentration of batik dye wastewater treatment after brush dyeing process. Since the concentration of existing dyes in related wastewater is less than other textile dyeing methods, applying these types of nano-membrane wastewater treatment methods can be reasonable and effective.

2. Experimental section

2.1. Materials

The fiber reactive dyes that were used in this study were obtained from TMS ART Company (KL, Malaysia), and were used directly without any purification. The molecular weight (MW), structure, and the other properties of the dyes are shown in Table 1.

Table 1
The dyes properties and characterization

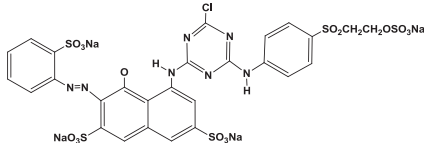
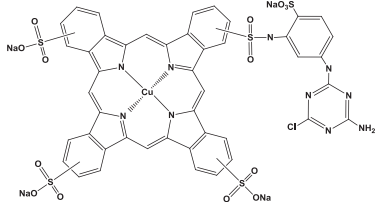
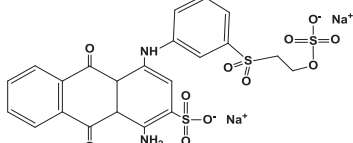
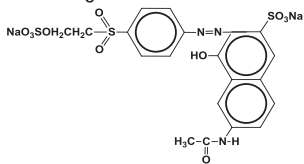
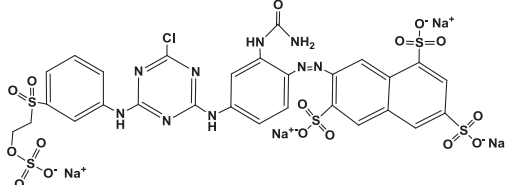
Commercial name	C-I	λ_{\max} (nm)	MW (g/mol)	Molecular formula	Structure formula
Reactive red 194	C.I. 18214	505	984.21	$C_{27}H_{18}ClN_7Na_4O_{16}S_5$	
Reactive blue 15	C.I.74459	674	1282.96	$C_{41}H_{19}ClCuN_{14}Na_4O_{14}S_5$	
Reactive black 5	C.I. 20505	600	626.549	$C_{22}H_{16}N_2O_{11}S_3 \cdot 2Na$	
Reactive orange 16	C.I. 17757	492	617.54	$C_{20}H_{17}N_3Na_2O_{11}S_3$	
Reactive yellow 145	C.I. 93050	419	1026.2	$C_{28}H_{20}ClN_9O_{16}S_5 \cdot 4Na$	

2.2. Equipment

The membrane filtration device was used to study the capability of nano-membranes in removing reactive dyes from synthetic dye wastewater. The nano-membrane filtration device was locally designed and fabricated. The flat sheet membrane module that was used was made from stainless steel. The metering pump was used to provide the flow pressure. The schematic diagram of the membrane filtration device is shown in Fig. 1.

The membrane chosen for this study was 4040-TS80-TSF-sheet membrane manufactured by TRISEP Corporation, CA, USA. The membrane was made from aromatic polyamide with non-woven fiberglass wound fibers support. According to the manufacturer, the MW cut off for the membrane was 200 Da. The rejection capabilities of the membrane specified by the manufacturer are shown in Table 2.

2.3. Sample preparation

Each dye sample was prepared based on the characteristic of the actual batik dye wastewater (0.5–30 mg/l). From that, synthetic dyes solution was prepared with a concentration of 16 mg/l in Milli-Q ultrapure water. Working volumes of 2 l were prepared for each dye liquor bath. The operating parameters for each test run were set at 25°C, 5 bar, and 60 min for temperature (T), pressure (P), and time, respectively. The permeability of membrane used in each filtration of dye solution was tested by ultra-pure water in a 30 min filtration run.

2.4. Sample coding

To simplify the presentation of the data, the dye samples used in this study were coded in the order as shown in Table 3.

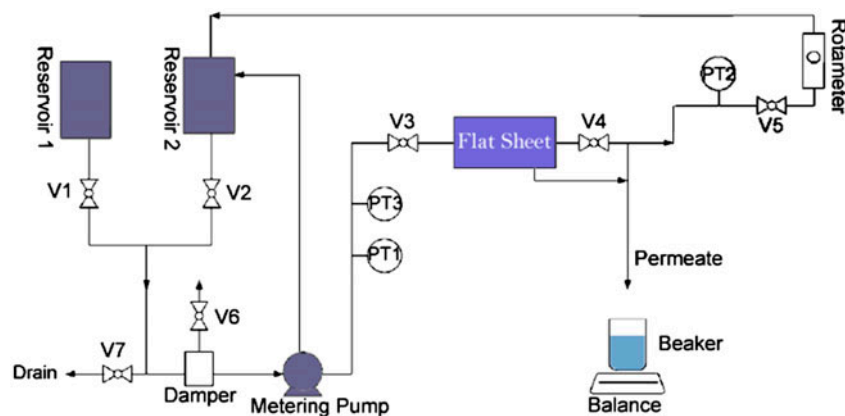

Fig. 1. NF apparatus setup.

Table 2
Nano-membrane characterization (based on specification given by manufacturer)

Model	Average salt rejection (%)	Minimum salt rejection (%)	Permeate flow GPD (m ³ /d)*
4040-TS80-TSF	99.00	97.00	2,000 (7.0)

*Performance is based on the following test condition: 2,000.0 ppm MgSO₄, 110.0 psi, 25 °C, 15% recovery, pH 8.0, 30 operation.

Table 3
Dye samples coding

Solution No	type	Dye	Code
1	Single	Reactive yellow 145	Y
2	Single	Reactive blue 15	TB
3	Single	Reactive orange 16	O
4	Single	Reactive red 194	R
5	Single	Reactive black 5	NB
6	Mixture	Reactive yellow 145 + Reactive blue 15	M2
7	Mixture	Reactive yellow 145 + Reactive blue 15 + Reactive orange 16	M3
8	Mixture	Reactive yellow 145 + Reactive blue 15 + Reactive orange 16 + Reactive red 194	M4
9	Mixture	Reactive yellow 145 + Reactive blue 15 + Reactive orange 16 + Reactive red 194+ Reactive black 5	M5

2.5. Analytical methods

In this study, low-range concentrations of synthetic dye wastewater treatment in the shortest possible time were tested for individual dye samples filtration process. The effects of the treatment parameters, such as flux, rejection, filtration efficiency, pressure difference (ΔP), pH, COD, and conductivity, on the nano-membrane filtration process in fixed filtration flow pressure were tested for 60 min. It is duly noted that in every filtration run of the same dye sample, the same membrane was used.

The feed dye solutions and permeate color intensity were measured by Thermo Scientific Genesis 20 visible spectrophotometer at a visible wavelength (325–750 nm), and analyzed by integration with absorbance curve. Rejection efficiencies ($R\%$) were calculated using Eq. (1):

$$R\% = 1 - \frac{C_p}{C_f} \times 100 \quad (1)$$

where C_f and C_p are feed and permeate dye concentrations, respectively.

The pH and conductivity range of each dye solution and permeate were measured using a Metrohm pH meter analyzer model 827(Swiss) and Cheetah multi parameter meters model DZS-708(China), respectively. The pure water flux (PWF) of each membrane, together with the dye solution, was observed and recorded using flux equation software.

The COD of each sample was tested for both before and after filtration using the HACH portable COD spectrophotometer, model DR/890(USA). Each experiment was repeated at least three times in order to ensure its accuracy and reproducibility.

3. Results and discussion

3.1. The effect of dyes on flux performance

The comparison between the PWFs and the dyes permeate fluxes for each filtration runs are shown in Fig. 2(a) and (b). From the Figures, the permeate fluxes for all of the single dye samples were within the range of 8.1–9 ml/cm²s. The lowest and highest flux values for single dyes goes to reactive black 5 (navy blue) and reactive blue 15 (turquoise blue), respectively. For dye mixture samples of nano-filtration, the highest flux value was observed for the mixture of five dyes. However, the other mixtures of dye samples have also showed the same pattern in the flux values.

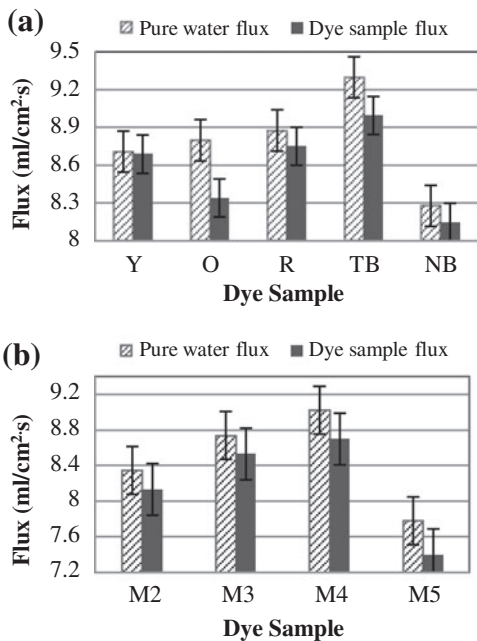

Fig. 2. Dye samples flux (a) single dye and (b) mixture dye.

These reductions in permeate fluxes for every filtration were due to the effect of capturing and trapping of the dye molecule groups into the membrane pores during the filtration processes. This occurs due to the formation of a partial filtration cake and gel layer on the membrane surface area, as well as a reduction in the fractional pore size and blockage by compounds absorbed via the membrane pores during the filtration cycle, thus decreasing the fluxes. The result is also consistent with the previous studies [42].

Previous studies have shown that the fouling during the treatment cycle will result in the reduction of flux permeation, thus decreasing the membranes' performance [43,44]. However, the changes of flux recorded for this experiment were unnoticeable, which can be concluded that the fouling phenomenon in this study was negligible.

Since the pore distribution on the nano-membrane surface area base was not homogenous, the initial PWFs of each filtration run recorded diverged between each membrane. Due to this reason, the normalized values between the fluxes of dye permeate and pure water were used as a basis of comparison.

Fig. 3 represents the relative fluxes for nano-filtration experiment carried out to all of the dye samples. The highest relative flux decline was observed for the orange dye followed by the mixture of five dyes (M5). The reactive orange dye sample showed a higher electrostatic charge behavior compared to the other single dye samples, since it contains higher value of OSO₃Na, SO₃Na, and CH₃CONH groups. Moreover, SO₂CH₂CH₂ and also β-sulfato derivative groups are the most important vinyl sulfone-masking group, with higher reactivity performance, existing in reactive orange dye. Based on these aspects, the reaction rate of reactive orange dye in constant concentration value (16 mg/l) was rather higher than other single dye samples [45].

Furthermore, a total number of charged groups in M5 were higher than the other mixtures since it contains all single dyes with same ratio. Accordingly, the

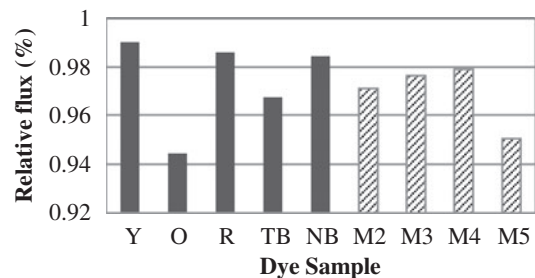

Fig. 3. Relative flux of dye samples.

trapping value of both orange and M5 dyes in membrane pores resulted significant decline in the fluxes due to the Donnan effect and rejection transpired phenomena [46].

On the other hand, the percentage of relative fluxes in M3 and M4 are slightly higher than M2 (Fig. 3). This phenomenon occurred due to the molecular size and weight in M2, which is rather higher. Moreover, in comparison with other mixtures, higher concentration ratio of reactive groups in Turquoise Blue and Yellow reactive dyes in M2 supports the mentioned reason, although hydrolyze occurs in separation process by leaving groups (especially SO_3Na groups) [45]. Accordingly, a higher level of fouling can be faced in M3 and M4.

3.2. The effect of nano-membrane filtration on the final pH of permeate

The pH value was measured for both feed dye solution and permeates of all tested dyes (Table 4). The result demonstrates a minor increase in the pH from the feed dye solution to permeate in all singles and mixtures of the dye samples. This can be explained by the reduced amount of reactive dyes found in the permeate, as a result from the filtration process. The removal of tested reactive dyes with acidic properties has caused the permeate samples' pH behaviors to enter the neutral region during the filtration process.

Additionally, this particular polyamide nano-membrane demonstrated negative charges when it reacts with the reactive dye solution, with less acidic characterization [47]. Then, the reactive dyes bond with polyamide surface by setting leaving groups free in acidic environment. The existing leaving groups in this reactive dyes contained Cl, OSO_3Na , SSO_3Na , OPO_3Na_2 , and SO_3Na components [45].

Consequently, the positive charges of reactive groups in dye molecule reacted with the membrane surface and ionic groups. It can be justified by Donnan exclusion effect [46], and rejection transpired [10,12,48]. Based on these phenomena, ethyl sulfones and aliphatic amines in the β -position were also transformed into leaving groups, which allow the lower

reactive groups to pass through the nano-membrane [45].

However, major differences of pH between feed and permeate samples were observed in reactive red 194 dye, and a mixture of reactive blue 15 and reactive yellow 145 for single dye solution samples and dyes mixture, respectively. This can be explained by the existence of chlorodiamino s-triazine reactive groups in dye samples structures, which exhibited strong reaction affinity behavior, and absorption to the nano-membranes' polyamide effective surface layer, rendering the reactive groups with acidic behavior in the permeate samples to be reduced [49].

On the other hand, the final pH of the samples taken from retentate was lower compared to the initial pH feed solution in each of the dyes samples. This was caused by the increased concentration of dye groups in reduced amount of water media in retentate compared to the feed dye solution.

3.3. The rejection and efficiency characteristic of filtered dye samples

Fig. 4 represents the high efficiencies of the nano-membrane in the dye molecule rejection process. The data were derived from the spectrophotometer curve in the visible range for each reactive dye solution samples, both pre- and post-filtration processes.

Table 4
Dye samples pH

Dye	NB	R	O	Y	TB	M2	M3	M4	M5
Feed pH	6.5	6.5	6.7	6.6	6.5	6.7	6.4	6.3	6.5
Permeate pH	6.9	6.8	6.9	6.8	6.8	7	6.6	6.5	6.8

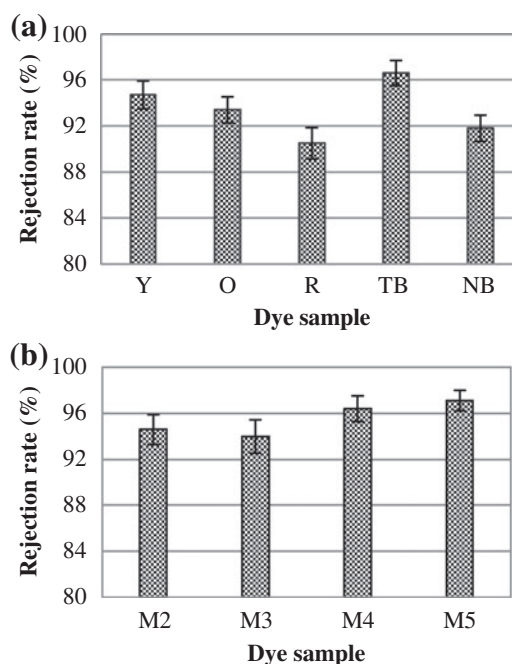

Fig. 4. (a) and (b) Single dye and mixture dyes samples rejection rate.

Nano-membranes demonstrated high rejection efficiencies in removing dye groups from the solution media. From Fig. 4, turquoise blue and yellow dyes had a higher rejection rate during membrane filtration and higher discoloring performance in permeates compared to the other dyes, due to higher MW and more electrostatic charged active groups.

The dye mixture samples showed the rejection rates to be in the range of 94–97%. Between all the mixture samples, the mixture of five dyes demonstrated a higher retaining rate due to the larger size of molecules and also the more different reactive groups (mainly multivalent charged ions) to react with the nano-membranes' effective polyamide layer compared with the other mixture of dyes. The rejection rate decreased significantly when the number of dyes in a mixture declines. However, for the mixture of two dyes, the results showed higher rejection rates compared to the mixture of 3 and 4 dyes. This can be explained by the presence of more chlorodiamino s-triazine reactive groups in this dye mixture sample, which affects the increasing affinity rate to react by polyamide nano-membrane. It is also in a good agreement with previous study [23].

The nano-membrane used in this study shows more than a 90% rejection efficiency rate in all testing runs for both single and dye mixture samples. This is also consistent with the previous studies [38,50]. This phenomenon can be explained by the dye samples' high ionic groups strength and molecule size (>600 g/mol) [12,51].

The differences in nano-membrane rejection efficiency value rates found in the current study dye solution samples can be elucidated by both the Donnan effect and the sieving mechanism [46]. The rejection efficiency and mechanism in nano-membranes directly depend on the electrostatic charge of separated foulants. For uncharged compounds separation, the rejection follows the sieving mechanism, which is based on the uncharged solutes; size exclusion and also the MW being transported through nano-membrane by distinctive pressures and flow rates [10,12,48,52].

On the other hand, the charged ions comply with Donnan (electrostatic) effect, and consequently, the results agree with previous studies on nano-membrane flat sheet rejection in reactive dye treatment, with similar results [31,53].

3.4. The effect of nano-membrane filtration on dyes' conductivity

The conductivity values of each dye sample's retentate and permeate solution was collected and tabulated (Fig. 5). The conductivity values for filtered dyes solutions were extensively reduced to lower than

10.7 $\mu\text{S}/\text{cm}$ compared to the initial value ranging between 25.5 and 42.6 $\mu\text{S}/\text{cm}$.

Total amount of suspended and dissolved ion in the aqueous phase specifies the electrical conductivity. Minor changes in conductivity values may signify possible reactions and consequent settling [54].

From these results, it can be concluded that the Donnan (electrostatic) effect plays a vital role in altering the conductivity value in the dye aqueous media separation process [46]. Due to this effect, the positive charge reactive dyes' groups (NaSO_3^+) are attracted to the negative charge (COO^-) polyamide nano-membrane active surface layer. Electrostatic interaction between dye reactive groups and the membrane takes place in the isoelectric high range zone (4.2 pl) and pH value of 6 [12]. Based on the effect that has been discussed, dissolved ions concentration (mainly multivalent) in all permeate samples declined, and consequently, the permeate conductivity values showed a considerable reduction compared to the retentate conductivity values.

3.5. The effect of nano-membrane filtration on COD

The COD value of each sample for both pre- and post-filtration process is shown in Table 5. The COD values in single dye solutions decreased to

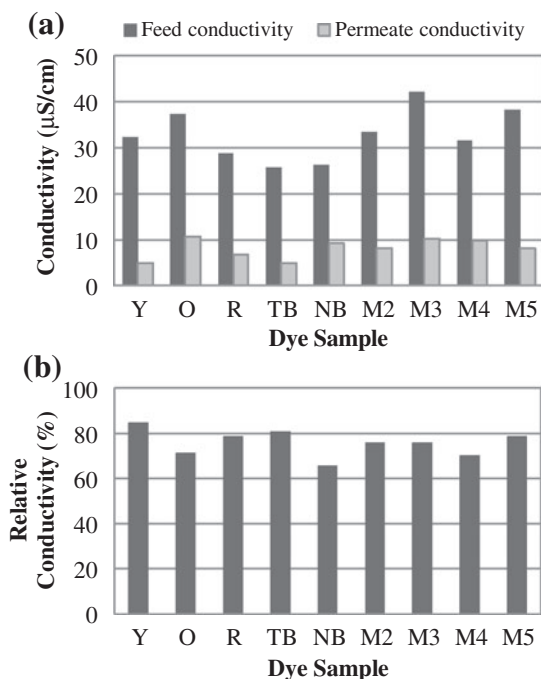

Fig. 5. (a) Dye samples conductivity and (b) relative conductivity.

Table 5
Dye samples COD properties

Dye	NB	R	O	Y	TB	M2	M3	M4	M5
COD Initial (mg/l)	19	16	14	11	11	9	6	6	3
COD Permeate (mg/l)	0	0	0	0	0	0	0	0	0

“non-detected” or nearly zero for post-filtration process, which led us to conclude the complete rejection efficiency for nano-membrane filtration. This occurred due to the removal of reactive group and dye color molecule during the filtration process by the nano-membrane polyamide active layer, based on separation mechanisms such as Donnan and steric exclusion, which plays significant roles in both separation and COD removing mechanisms [9,31,53]. The COD value in all dye solution samples was not more than 20 mg/l, since only reactive dye dissolved in distilled water and both organic and inorganic components were not applied.

During pre-filtration, the COD values of mix dyes solutions were lower (3–9 mg/l) compared to the single dye feed samples (11–19 mg/l). These phenomena occurred due to the hydrolysis of fiber reactive dyes in mix dye samples. Hydrolyzed reactive dyes with low molecular divalent and monovalent ionic behavior caused a sharp decrease in the COD factor in the dye samples that are being studied [55]. At this point, the increasing number of the reactive groups in dye reduces the COD values, precipitating the increase of the hydrolysis rates in the samples.

Also, a strong H-bonding and covalent bonding were formed between the nano-membrane and the reactive dyes, since each of the dye samples has a higher MW and larger molecular structures compared to the nano-membranes' pore size, most of the dye molecules were found to be attached and captured by the nano-membrane during the filtration process.

4. Conclusions

The permeability of the nano-membrane flat sheet during each dye samples filtration was evaluated. The permeate flux in all of the samples was between 7.8 and 9.25 ml/cm²s. The slight flux decline that recorded was due to the trapping and attachment of the dye molecules on the nano-membrane during the filtration process. The rejection rate in nano-membranes was in the range of 90–97%, and is based on structures, sizes, and the electrical charge of dye molecules in each sample. The permeate pH in every dye samples was increased to almost the natural range

compare to the dye samples, which exhibited slightly an acidic behavior. The COD in all single dye samples retentate with slightly more than zero area went to samples permeates, which had zero amounts in post-filtration. In mix dye samples, the COD in retentate had a value from 9 to 3 mg/l due to the hybridization in the reactive groups. The conductivity in all of the samples declined sharply during the nano-filtration process.

Acknowledgments

The authors in this projects would like to express the gratefulness and appreciation to PPP grant (Project No. PV092-2011B) and UMRG grant (Project No. RG151-12SUS) of University of Malaya (UM) to support the project and share the UM facilitates for developing the project.

References

- [1] E. Ellouze, N. Tahri, R.B. Amar, Enhancement of textile wastewater treatment process using nanofiltration, *Desalination* 286 (2012) 16–23.
- [2] Y. He, G. Li, H. Wang, Z. Jiang, J. Zhao, H. Su, Q. Huang, Diafiltration and water recovery of reactive brilliant blue KN-R solution by two-stage membrane separation process, *Chem. Eng. Process.* 49 (2010) 476–483.
- [3] T. Robinson, G. McMullan, R. Marchant, P. Nigam, Remediation of dyes in textile effluent: A critical review on current treatment technologies with a proposed alternative, *Bioresour. Technol.* 77 (2001) 247–255.
- [4] H. Rashidi, N. Sulaiman, N. Hashim, Batik industry synthetic wastewater treatment using nanofiltration membrane, *Procedia Eng.* 44 (2012) 2010–2012.
- [5] D. Wambuguh, R.R. Chianelli, Indigo dye waste recovery from blue denim textile effluent: A by-product synergy approach, *New J. Chem.* 32 (2008) 2189–2194.
- [6] T.D. Martins, D. Schimmel, J.o.B. dos Santos, E.A. da Silva, Reactive blue 5G adsorption onto activated carbon: Kinetics and equilibrium, *J. Chem. Eng. Data* 58 (2012) 106–114.
- [7] M. Greluk, Z. Hubicki, Evaluation of polystyrene anion exchange resin for removal of reactive dyes from aqueous solutions, *Chem. Eng. Res. Des.* 91 (2013) 1343–1351.

- [8] C. Terras, P. Vandevivere, W. Verstraete, Optimal treatment and rational reuse of water in textile industry, *Water Sci. Technol.* 39 (1999) 81–88.
- [9] A. Yadav, S. Mukherji, A. Garg, Removal of chemical oxygen demand and color from simulated textile wastewater using a combination of chemical/physico-chemical processes, *Ind. Eng. Chem. Res.* 52 (2013) 10063–10071.
- [10] G. Dupont, *La teinture [Dyeing]*, Les Editions de l'industrie textile [Textile industry publishing], France, 2002.
- [11] Z. Mbolekwa, C. Buckley, The Removal of Reactive Dyes from Dye Liquor Using Activated Carbon for the Reuse of Salt, Water Energy, Water Research Commission, Pretoria, 2008.
- [12] A. Akbari, J. Remigy, P. Aptel, Treatment of textile dye effluent using a polyamide-based nanofiltration membrane, *Chem. Eng. Process.* 41 (2002) 601–609.
- [13] H.R. Rashidi, N.M. Sulaiman, N.A. Hashim, C.R. Che Hassan, Synthetic batik wastewater pretreatment progress by using physical treatment, *Adv. Mater. Res.* 627 (2013) 394–398.
- [14] W.-J. Lau, A. Ismail, Polymeric nanofiltration membranes for textile dye wastewater treatment: Preparation, performance evaluation, transport modelling, and fouling control—A review, *Desalination* 245 (2009) 321–348.
- [15] X. Ouyang, W. Li, S. Xie, T. Zhai, M. Yu, J. Gan, X. Lu, Hierarchical CeO₂ nanospheres as highly-efficient adsorbents for dye removal, *New J. Chem.* 37(3) (2013) 585–588.
- [16] J. Blanco, F. Torrades, M. De la Varga, J. García-Montaño, Fenton and biological-Fenton coupled processes for textile wastewater treatment and reuse, *Desalination* 286 (2012) 394–399.
- [17] G.E. Üstün, S.K.A. Solmaz, A. Birgül, Regeneration of industrial district wastewater using a combination of Fenton process and ion exchange—A case study, *Resour. Conserv. Recycl.* 52 (2007) 425–440.
- [18] C. Tizaoui, N. Grima, Kinetics of the ozone oxidation of reactive orange 16 azo-dye in aqueous solution, *Chem. Eng. J.* 173 (2011) 463–473.
- [19] Y.-H. Huang, S.-T. Tsai, Y.-F. Huang, C.-Y. Chen, Degradation of commercial azo dye reactive black B in photo/ferrioxalate system, *J. Hazard. Mater.* 140 (2007) 382–388.
- [20] M.H. Santana, L.M. Da Silva, A.C. Freitas, J.F. Boodts, K.C. Fernandes, L.A. De Faria, Application of electrochemically generated ozone to the discoloration and degradation of solutions containing the dye reactive orange 122, *J. Hazard. Mater.* 164 (2009) 10–17.
- [21] T. Robinson, B. Chandran, P. Nigam, Removal of dyes from a synthetic textile dye effluent by biosorption on apple pomace and wheat straw, *Water Res.* 36 (2002) 2824–2830.
- [22] A. Pala, E. Tokat, Color removal from cotton textile industry wastewater in an activated sludge system with various additives, *Water Res.* 36 (2002) 2920–2925.
- [23] A.D. Dhale, V.V. Mahajani, Reactive dye house wastewater treatment. Use of hybrid technology: Membrane, sonication followed by wet oxidation, *Ind. Eng. Chem. Res.* 38 (1999) 2058–2064.
- [24] S. Raghu, C. Ahmed Basha, Chemical or electrochemical techniques, followed by ion exchange, for recycle of textile dye wastewater, *J. Hazard. Mater.* 149 (2007) 324–330.
- [25] S. Ahmed, M. Seraji, J. Jahedi, M. Hashib, Application of CFD for simulation of a baffled tubular membrane, *Chem. Eng. Res. Des.* 90 (2012) 600–608.
- [26] K.K. Sirkar, Membranes, phase interfaces, and separations: Novel techniques and membranes an overview, *Ind. Eng. Chem. Res.* 47 (2008) 5250–5266.
- [27] I. Petrić, N.P.R. Andersen, S. Šostar-Turk, A.M. Le Marechal, The removal of reactive dye printing compounds using nanofiltration, *Dyes Pigm.* 74 (2007) 512–518.
- [28] N. Hilal, H. Al-Zoubi, N. Darwish, A. Mohamma, M. Abu Arabi, A comprehensive review of nanofiltration membranes: Treatment, pretreatment, modelling, and atomic force microscopy, *Desalination* 170 (2004) 281–308.
- [29] S. Babursah, M. Çakmakci, C. Kinaci, Analysis and monitoring: Costing textile effluent recovery and reuse, *Filtr. Sep.* 43 (2006) 26–30.
- [30] K. Ranganathan, K. Karunakaran, D. Sharma, Recycling of wastewaters of textile dyeing industries using advanced treatment technology and cost analysis—Case studies, *Resour. Conserv. Recycl.* 50 (2007) 306–318.
- [31] M. Marcucci, L. Tognotti, Reuse of wastewater for industrial needs: The Pontedera case, *Resour. Conserv. Recycl.* 34 (2002) 249–259.
- [32] P. Nigam, G. Armour, I. Banat, D. Singh, R. Marchant, Physical removal of textile dyes from effluents and solid-state fermentation of dye-adsorbed agricultural residues, *Bioresour. Technol.* 72 (2000) 219–226.
- [33] G. Ciardelli, L. Corsi, M. Marcucci, Membrane separation for wastewater reuse in the textile industry, *Resour. Conserv. Recycl.* 31 (2001) 189–197.
- [34] M. Riera-Torres, C. Gutiérrez-Bouzán, M. Crespi, Combination of coagulation–flocculation and nanofiltration techniques for dye removal and water reuse in textile effluents, *Desalination* 252 (2010) 53–59.
- [35] A. Aouni, C. Fersi, B. Cuartas-Urbe, A. Bes-Pía, M. Alcaina-Miranda, M. Dhahbi, Reactive dyes rejection and textile effluent treatment study using ultrafiltration and nanofiltration processes, *Desalination* 297 (2012) 87–96.
- [36] S.P. Sun, T.A. Hatton, S.Y. Chan, T.-S. Chung, Novel thin-film composite nanofiltration hollow fiber membranes with double repulsion for effective removal of emerging organic matters from water, *J. Membr. Sci.* 401 (2012) 152–162.
- [37] N. Tahri, G. Masmoudi, E. Ellouze, A. Jrad, P. Drogui, R. Ben Amar, Coupling microfiltration and nanofiltration processes for the treatment at source of dyeing-containing effluent, *J. Cleaner Prod.* 33 (2012) 226–235.
- [38] S. Avlonitis, I. Poulis, D. Sotiriou, M. Pappas, K. Moutesidis, Simulated cotton dye effluents treatment and reuse by nanofiltration, *Desalination* 221 (2008) 259–267.
- [39] Z. Amjad, *Reverse Osmosis: Membrane Technology, Water Chemistry & Industrial Applications*, Chapman & Hall, Norwell, MA, 1993.

- [40] C.Y. Tang, T. Chong, A.G. Fane, Colloidal interactions and fouling of NF and RO membranes: A review, *Adv. Colloid Interface Sci.* 164 (2011) 126–143.
- [41] J. Huang, K. Zhang, The high flux poly (m-phenylene isophthalamide) nanofiltration membrane for dye purification and desalination, *Desalination* 282 (2011) 19–26.
- [42] A. Schäfer, A.G. Fane, T. Waite, Fouling effects on rejection in the membrane filtration of natural waters, *Desalination* 131 (2000) 215–224.
- [43] J. Vrouwenvelder, J. Kappelhof, S. Heijman, J. Schippers, D. Van der Kooija, Tools for fouling diagnosis of NF and RO membranes and assessment of the fouling potential of feed water, *Desalination* 157 (2003) 361–365.
- [44] W.-J. Lau, A.F. Ismail, Polymeric nanofiltration membranes for textile dye wastewater treatment: Preparation, performance evaluation, transport modelling, and fouling control—A review, *Desalination* 245 (2009) 321–348.
- [45] A.H.M. Renfrew, *Reactive Dyes for Textile Fibres*, Society of Dyers and Colourists, West Yorkshire, 1999.
- [46] P. Denyer, L. Shu, V. Jegatheesan, Evidence of changes in membrane pore characteristics due to filtration of dye bath liquors, *Desalination* 204 (2007) 296–306.
- [47] L. Bruni, S. Bandini, The role of the electrolyte on the mechanism of charge formation in polyamide nanofiltration membranes, *J. Membr. Sci.* 308 (2008) 136–151.
- [48] M. Elkady, A.M. Ibrahim, M. El-Latif, Assessment of the adsorption kinetics, equilibrium and thermodynamic for the potential removal of reactive red dye using eggshell biocomposite beads, *Desalination* 278 (2011) 412–423.
- [49] E. Siegel, Chapter I—Reactive dyes: Reactive groups, in: K. Venkataraman (Ed.) *The Chemistry of Synthetic Dyes*, Academic Press, Burlington, MA, 1972, pp. 1–209.
- [50] J.-J. Qin, M.H. Oo, K.A. Kekre, Nanofiltration for recovering wastewater from a specific dyeing facility, *Sep. Purif. Technol.* 56 (2007) 199–203.
- [51] B. Van der Bruggen, E. Curcio, E. Drioli, Process intensification in the textile industry: The role of membrane technology, *J. Environ. Manage.* 73 (2004) 267–274.
- [52] B. Van der Bruggen, C. Vandecasteele, Removal of pollutants from surface water and groundwater by nanofiltration: Overview of possible applications in the drinking water industry, *Environ. Pollut.* 122 (2003) 435–445.
- [53] A. Sungpet, R. Jiratananon, P. Luangsowan, Treatment of effluents from textile-rinsing operations by thermally stable nanofiltration membranes, *Desalination* 160 (2004) 75–81.
- [54] S. Venkata Mohan, N. Chandrasekhar Rao, K. Krishna Prasad, J. Karthikeyan, Treatment of simulated reactive yellow 22 (Azo) dye effluents using *Spirogyra* species, *Waste Manage.* 22 (2002) 575–582.
- [55] C. Allègre, P. Moulin, M. Maisseu, F. Charbit, Treatment and reuse of reactive dyeing effluents, *J. Membr. Sci.* 269 (2006) 15–34.