

Split partial second pass design for SWRO plants

Stefan Rybar, Roman Boda*, Craig Bartels

Hydranautics – A Nitto Denko Company, 401 Jones Road, Oceanside, CA 92058, United States
Tel. +1 (44) 141 6462207; Fax + 1 (44) 7899075549; email: rboda@hydranautics.nl

Received 30 April 2009; accepted 18 October 2009

ABSTRACT

All over the world, the reverse osmosis (RO) desalination plants are providing populations and industries with high quality freshwater. There are various requirements on water quality produced by RO desalination plants depending on final purpose of water usage. In recent years, the requirement for low Boron concentrations in RO permeate was the main parameter to be considered in designing many seawater RO systems. Beside the development of new RO membranes with improved Boron rejection, there are also other design options which can help to achieve required product quality. One of such options is also Split Partial Second Pass (SPSP) RO design.

The principle of a SPSP design is based on the fact, that front elements in RO pressure vessel are always producing better permeate quality than elements at the back of the pressure vessel. In order to take advantage of better permeate quality at the front of the vessel in SPSP design, permeate is collected from both sides of the pressure vessel. Low TDS front permeate is then sent directly to final product line, while higher TDS back permeate is treated by partial second pass RO plant. At the end of the process, both permeate streams are blended together to create the final product of required quality. The SPSP design allows to select the right ratio between front and back permeate in order to obtain final product of required quality in terms of Boron, TDS and other quality parameters. The SPSP design provides cost effective option by minimizing the size of the second pass RO, which allows substantial savings on capital investments as well as in operating cost of the plant.

This paper will present in more details the SPSP design option and requirements, the important parameters influencing SPSP design and different ways of the control, and finally it will discuss benefits and savings resulting from this RO design option. It will also present actual operating data from seawater RO plant using this design option.

Keywords: reverse osmosis; split partial second pass; boron

1. Introduction

In recent years, many large seawater reverse osmosis (SWRO) plants were designed and are being built with very strict requirements on final product quality. It is not unusual, that very low concentrations of TDS, Chlorides, Bromides and Boron are requested by plant

end users. Despite the latest development of high TDS and Boron rejection seawater and brackish water reverse osmosis (RO) membranes, such requirements very often leave membrane suppliers and plant designers with no other option than consider SWRO design with full two pass configuration in order to comply with permeate quality demands. Many times it is necessary to consider full two pass RO design to achieve required concentration of just one parameter,

*Corresponding author

Presented at the conference on Desalination for the Environment: Clean Water and Energy, 17–20 May 2009, Baden-Baden, Germany. Organized by the European Desalination Society.

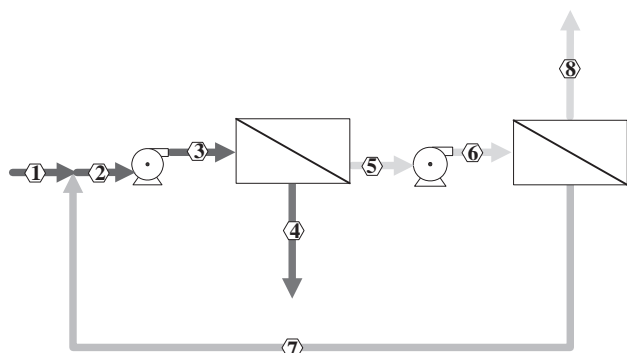

Fig. 1. Full second pass flow diagram.

while other parameters are easily achievable with less expensive, partial two pass design. Very strict Boron (usually < 0.5 or < 0.3 mg/l) and recently also Chlorides (< 20–30 mg/l) requirements on newly designed SWRO plants are usually the main drivers deciding between full and partial two pass RO design.

Although the conventional partial two pass design can reduce the second pass size, many times it is not maximizing possible savings on second pass size reduction.

2. Two pass RO design options

There are two main design option of two pass RO system, depending on the final product quality requirements.

2.1. Full second pass

100% of permeate flow from first pass RO is treated by second pass RO to obtain required product quality and quantity

Typical recovery of two pass SWRO system: First pass – 50%, Second pass – 90%, Total – 47% with second pass brine recycle (Fig. 1)

2.2. Partial second pass

Portion of the first pass RO permeate is treated by second pass RO and permeate from both RO passes is blended together to achieve final product of required quality and quantity.

Typical recovery of partial two pass SWRO system: First pass – 50%, Second pass – 90%, Total – 48.5% with second pass brine recycle (Fig. 2)

Partial second pass system has the following main advantages against full second pass design:

- Smaller second pass RO trains
- Higher total system recovery

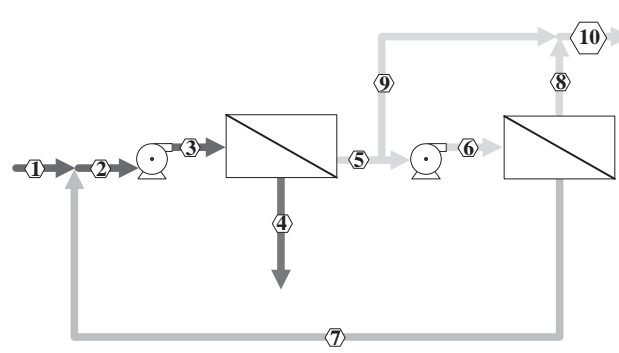

Fig. 2. Partial second pass flow diagram.

- Reduced capital cost (number of pressure vessels and membranes, smaller foot print, less high pressure piping and fittings)
- Reduced operating cost (lower energy and chemical consumption, less maintenance, smaller quantity of spare parts, reduced replacement and storage cost of RO membranes)

3. Split partial second pass RO design concept

Split Partial Second Pass (SPSP) RO design is advanced partial two pass RO configuration, which fully utilizes detail knowledge of RO membranes performance within pressure vessel with multiple membranes as are usually used on large RO plants. This process has been proposed initially by Mr. D. Bray [1] in the past. When properly used, it can largely reduce the size of second pass RO plant and save significant amount of capital and operating cost when compared to conventional full or partial two pass RO design.

In typical operation of the SWRO plant with multiple elements working in pressure vessel, the front RO elements are producing higher flow of low salinity permeate than elements at the back of the pressure vessel. Below charts show typical combined salinity and flux distribution in pressure vessel with eight high rejection seawater RO membranes. First 3–4 membranes are usually producing highest permeate flow with best quality (Figs. 3 and 4).

As it can be seen on chart below (Fig. 5) showing test results conducted with Hydranautics SWC3 elements on seawater feed, the first 4–5 elements in pressure vessel are usually producing about 70–80% of the total permeate flow with combined salinity of less than 300 mg/l. The rest of the elements is producing remaining permeate flow with combine salinity of above 1500 mg/l.

This detailed knowledge of flow and salinity distribution within pressure vessel is fully utilized in SPSP

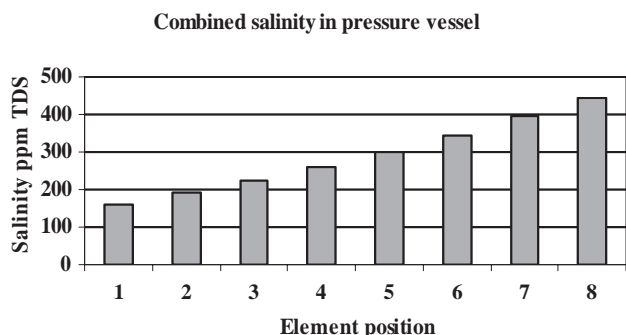

Fig. 3. Combined salinity in 8 elements seawater reverse osmosis (SWRO) pressure vessel.

design concept. In the SPSP design, the first pass permeate is collected from both sides of the pressure vessels. Front permeate with very good quality is directly sent to product tank, while rear permeate which has high salinity is treated by second pass RO. The second pass RO permeate is blended together with front permeate from first pass RO in product tank. Basically, it means that the second pass treats a smaller, but more saline stream than a traditional partial two-pass system. With such arrangement, it is possible to maximize the size reduction of second pass RO when compared to conventional partial second pass design. This also has the advantage of increasing the overall recovery and results in reducing the size of the first pass and the pretreatment. Hydranautics IMSD software is simple and easy to use tool to model the SPSP design. It allows optimization of the second pass RO size according to requirements on the final product quality. It was developed mainly to achieve low Boron concentration in RO permeate and minimize the size of second pass as well as chemical and power consumption.

The following are the main parameters influencing the SPSP design:

- Feed water salinity and temperature range – with lower feed salinity and temperature it is possible to design smaller 2nd pass.
- 1st and 2nd pass feed water pH – this is particularly important for Boron rejection. It is well known, that high pH of 10 and above must be used to obtain good level of boron rejection. Seawater feed alkalization (patented by Hydranautics) can significantly reduce the size of 2nd pass.
- Selection of the 1st and 2nd pass RO membranes (high salt rejection, energy saving, high boron rejection) – highest rejection membranes can significantly reduce the size of 2nd pass, but it is usually at the cost of higher feed pressure and consequent energy consumption. Therefore, the high rejection – low pressure energy saving membranes are usually used on SPSP design.
- Selected membrane age/replacement rate – higher replacement rate on 1st pass RO will reduce averaged membrane age, improve permeate quality and reduce the size of 2nd pass and vice versa.
- Selected design permeate flux – good performance of pre-treatment allows to use higher permeate flux on 1st pass RO design, which has positive effect on permeate quality and size of the 2nd pass RO. On the other side, higher flux will require higher feed pressure.
- Product quality requirements (TDS, Boron, Chlorides, Bromides etc.)

4. Mechanical design options of system with SPSP

Generally, there are two basic design option of system operating in SPSP mode, each bringing different level of flexibility and requires different equipment and capital cost.

More simple and less expensive option is design based on the fixed split ratio between front and back permeate on the first pass RO. It can be achieved by installing a permeate plug on certain membrane position inside the pressure vessel to separate front and back permeate. Permeate plug is usually installed after 3rd or 4th RO membrane, as these are elements producing best permeate quality. Typical diagram of such system is shown on Fig. 6 below.

As the front to back permeate split ratio is fixed with above design, the front permeate flow can not be changed according to actual membrane performance, feed water quality and temperature. The second pass RO usually works at fixed flux with this design and permeate quality depends on feed water supplied by back SWRO membranes from first pass. It is very likely, that each SWRO system will experience

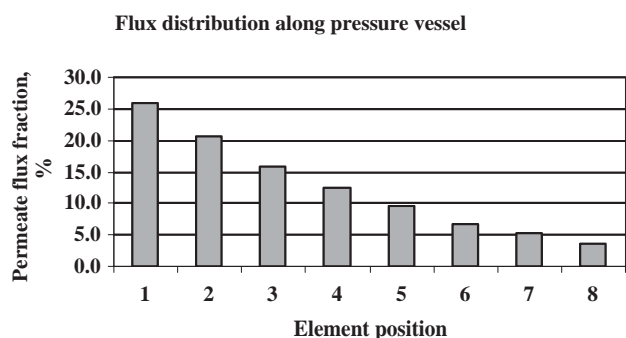

Fig. 4. Flux Distribution in 8 elements seawater reverse osmosis (SWRO) pressure vessel.

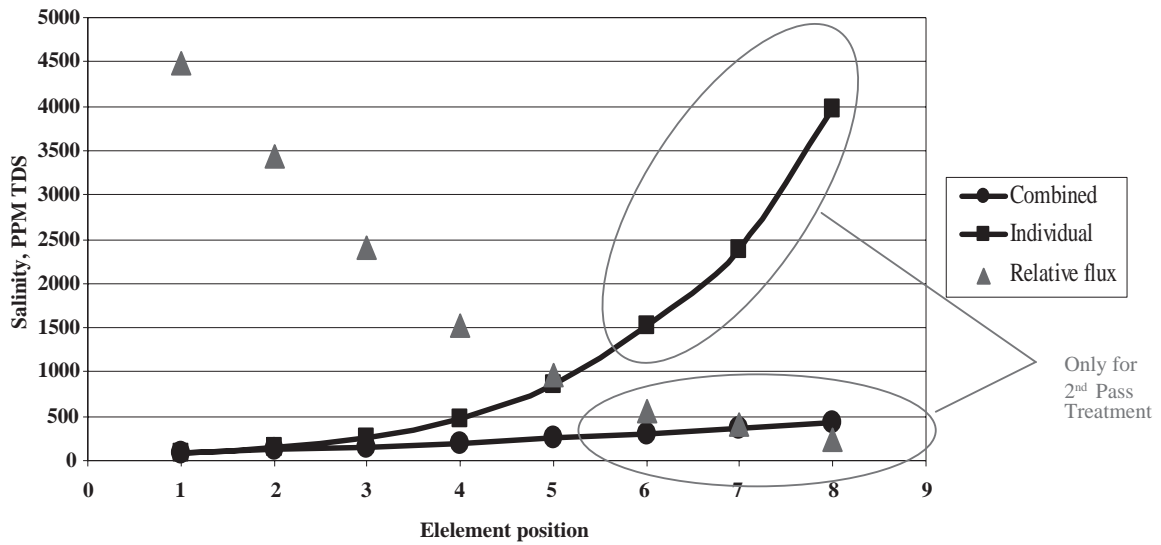

Fig. 5. SWC3 flux and salinity distribution in 8 elements PV.

fouling after some time of operation. As the lead elements in position 1 and 2 are usually most affected by particulate fouling or biofouling, it can have quite significant influence on operation of SPSP design with fixed split ratio. With loss of flux due to fouling on lead elements, the split ratio can be changed significantly without possibility of re-adjustment. This will result in change of performance of second pass RO with impact on overall permeate quality and operating cost.

In order to overcome above mentioned possible problems with operation of SPSP design and bring

more flexibility into operation of SPSP system, Hydraulics proposes mechanical design of SPSP RO utilizing flow control valves (FCV) on one or both permeate lines to control permeate split ratio. It is clear, that such design will require slightly higher capital cost due to additional valves and control sequences, but it will allow for bigger flexibility in system operation and help to reduce overall operating cost. Typical diagram of SPSP system with FCVs on permeate lines can be seen on Figs. 7 and 8. The FCVs allows continuous adjustment of front and back permeate flow according

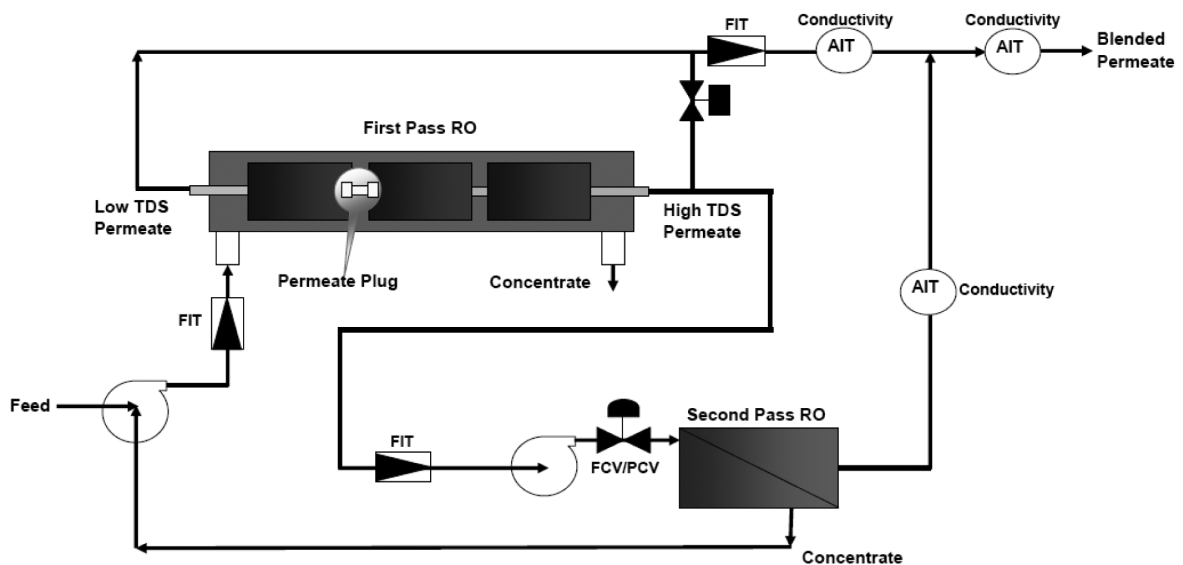

Fig. 6. Typical diagram of SPSP with fixed split ratio.

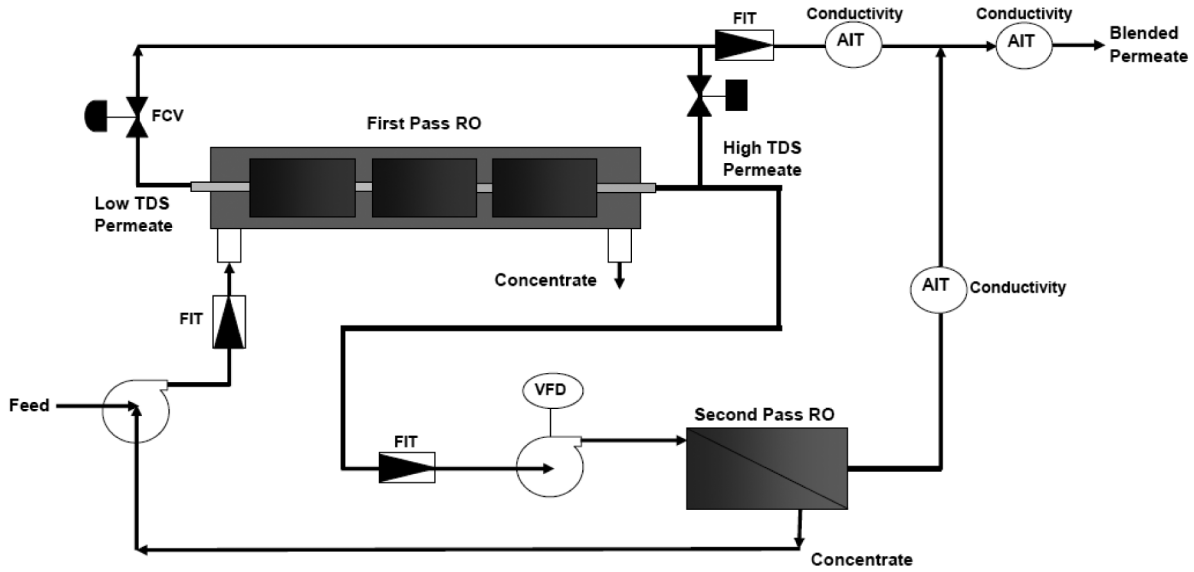

Fig. 7. Typical diagram of SPSP with variable split ratio.

to actual membrane performance, feed water salinity and temperature. It also gives possibility to run system in single pass mode via back permeate by-pass valve, which might be the case when membranes are new and feed water temperature is low. In such case the final permeate quality could be obtained by first pass RO operation only. Changing the permeate split ratio on first pass RO will require second pass high pressure pump motor to be equipped with variable frequency

drive in order to operate second pass at different flux/capacity according to actual conditions. There are two possibilities of split ratio adjustment. First option is changing the flow set points for front and back permeate until required quality is obtained in blended product. Second option is to use output from online conductivity meters on permeate lines to re-adjust split ratio until set conductivity value is obtained in blended product.

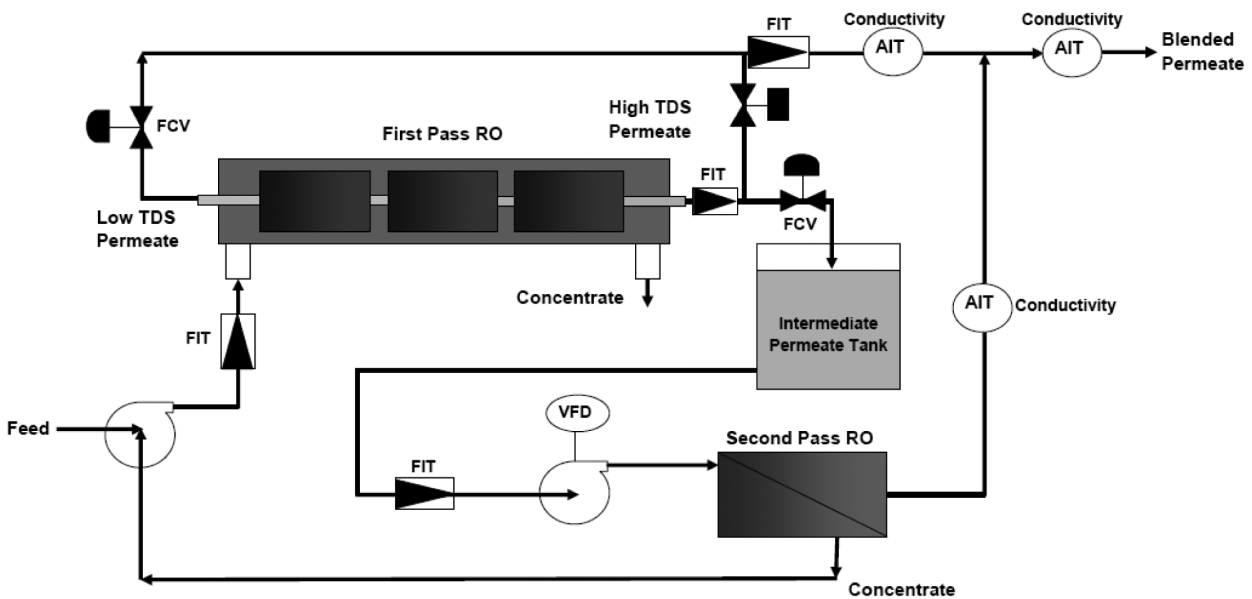

Fig. 8. Typical diagram of SPSP with variable split ratio and intermediate tank.

Table 1
Comparison of Conventional and Split Partial 2nd Pass Design

Design comparison	Split partial 2nd pass	Partial 2nd pass
Number of trains – 1st pass	16	16
Number of trains – 2nd pass	8	8
Number of PVs – SWRO	163	167
Elements per PV	7	7
1st pass element type	SWC 440 ft ²	SWC 440 ft ²
Number of SWC elements	18,256	18,704
1st pass permeate flow @ 21 °C	16,250 m ³ /day	16,592.2 m ³ /day
1st Pass permeate flow @ 36 °C	16,250 m ³ /day	16,592.2 m ³ /day
1st Pass permeate recovery	42%	42%
1st Pass feed P @ 21 °C	65.9 Bar	65.3 Bar
1st Pass feed P @ 36 °C	63.9 Bar	63.3 Bar
1st Pass permeate TDS @ 36 °C – Back	626.6	481.6
Difference in PV qty – 1st pass	–64	64
Number of PVs – 1st stage BWRO	64	81
Number of PVs – 2nd Stage BWRO	20	26
1st Pass Flux/2nd pass flux	14.5/35.3 l/m ² /h	14.5/35.4 l/m ² /h
Difference in PV qty – 2nd pass	–184	184
2nd pass permeate flow @ 21 °C	20,340 m ³ /day	26,500 m ³ /day
2nd pass permeate flow @ 36 °C	20,340 m ³ /day	26,500 m ³ /day
2nd pass permeate recovery	90%	90%
2nd pass feed P @ 21 °C	11.9 Bar	11.8 Bar
2nd pass feed P @ 36 °C	9.3 Bar	9.1 Bar
2nd pass permeate TDS @ 36 °C	25 mg/l	16.25 mg/l
Blended permeate TDS @ 36 °C	73.6 mg/l	74.36 mg/l
Energy consumption		
Pump efficiency/Motor efficiency	85%/95%	85%/95%
Energy consumption – 1st pass @ 21 °C	1,403,345 kWh/day	1,462,446.7 kWh/day
Energy saving – 1st pass @21 °C	–59,101.7 kWh/day	
Energy consumption – 1st pass @ 36 °C	1,360,754.8 kWh/day	1,376,364.1 kWh/day
Energy saving – 1st pass @ 36 °C	–15,609.3 kWh/day	
Energy saving – 1st pass – averaged	–37,356 kWh/day	
Energy consumption – 2nd pass @ 21 °C	148,023 kWh/day	187,075 kWh/day
Energy saving – 2nd pass @ 21 °C	–39,051 kWh/day	
Energy Consumption – 2nd pass @ 36 °C	115,682 kWh/day	147,475 kWh/day
Energy saving – 2nd pass @ 36 °C	–31,793 kWh/day	
Energy saving – 2nd pass – averaged	–35,422 kWh/day	
Energy saving – 1st + 2nd pass	–72,778 kWh/day	
Energy saving US\$/year @ US\$ 0.016/kWh & 95% availability	–403,771 US\$	

Bold formatting is used to highlight the savings in CAPEX and OPEX

The SPSP RO design with FCV brings the following benefits against conventional partial second pass design:

- Slight reduction in the size of the first pass RO and pretreatment
- Further reduction in size of second pass RO
- Better permeate quality
- Fewer membranes and pressure vessels to produce same permeate flow
- Reduced capital and operating cost (less membranes, less piping, less maintenance, lower chemical and power consumption)

- Flexibility in system operation according to actual conditions (membrane age, fouling, feed water salinity and temperature)

The difference between partial second pass and SPSP decreases with increased capacity of second pass RO.

5. Comparison of partial and split partial second pass design

Case study was performed by Hydranautics on large SWRO plant design with Red Sea water feed to

Table 2
SWRO Plants using Split Partial Second Pass design with Hydranautics RO membranes

Plant name	Plant capacity (m ³ /day)	SWRO membranes	BWRO membranes
Larnaca (Cyprus)	54,000	SWC3 and SWC4	ESPA2 (1st stage) and CPA3 (2nd stage)
Dhekelia (Cyprus)	51,850	SWC5	ESPAB
Gold Coast (Australia)	133,000	SWC5	ESPA2

compare conventional and split partial second pass design. High rejection and high flow SW membranes were used on first pass RO design. Results are summarized in below table which shows clear advantage of SPSP design in all compared parameters (Table 1).

The following formula was used to calculate power consumption for RO Train:

$$P = ((Q * SG * TDH / 102 * P\eta) / M\eta) * 24h$$

- Where: *P* – pump power (kW)
- Q* – Feed flow in (L/sec)
- SG* – fluid spec.gravity in (kg/L) = 1
- TDH* – total developed head in (m)
- Pη* – Pump efficiency
- Mη* – Motor efficiency

As it can be seen from above comparison, the SPSP design reduced the size of 2nd pass RO by 23%, required number of 2nd pass membranes and pressure vessels by 21% and overall RO energy consumption by 4.6%. On the top of above mentioned savings, there will

be additional savings on high pressure pipes and fittings, 2nd pass foot print, membrane loading and replacement cost.

6. Practical experience from operation of split partial second pass design

SPSP design has become accepted approach by desalination industry and there are already few large desalination plants in the world successfully using SPSP design concept (Larnaca, Dhekelia, Tampa, Gold Coast, Ashkelon).

Hydranautics membranes are used on few of these plants, namely on (Table 2):

6.1. Larnaca SWRO desalination plant experience [2]

Larnaca SWRO desalination plant was one of the first plants to adopt strict Boron requirements and first major SWRO desalination plant to use SPSP design concept (Fig. 9).

The SPSP design gives additional flexibility to Larnaca plant operation. During the periods with low

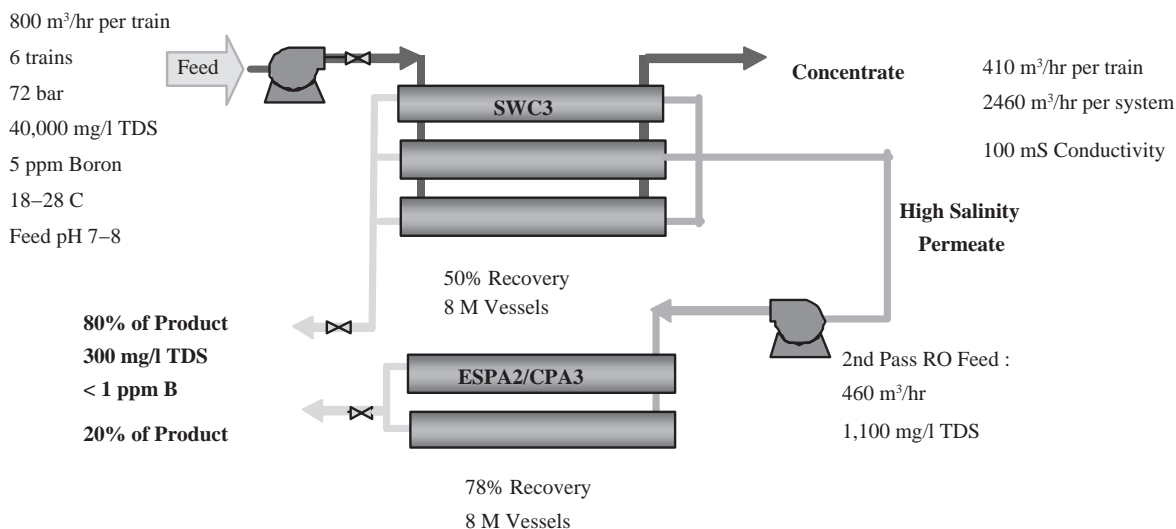

Fig. 9. Flow diagram of Larnaca SWRO plant.

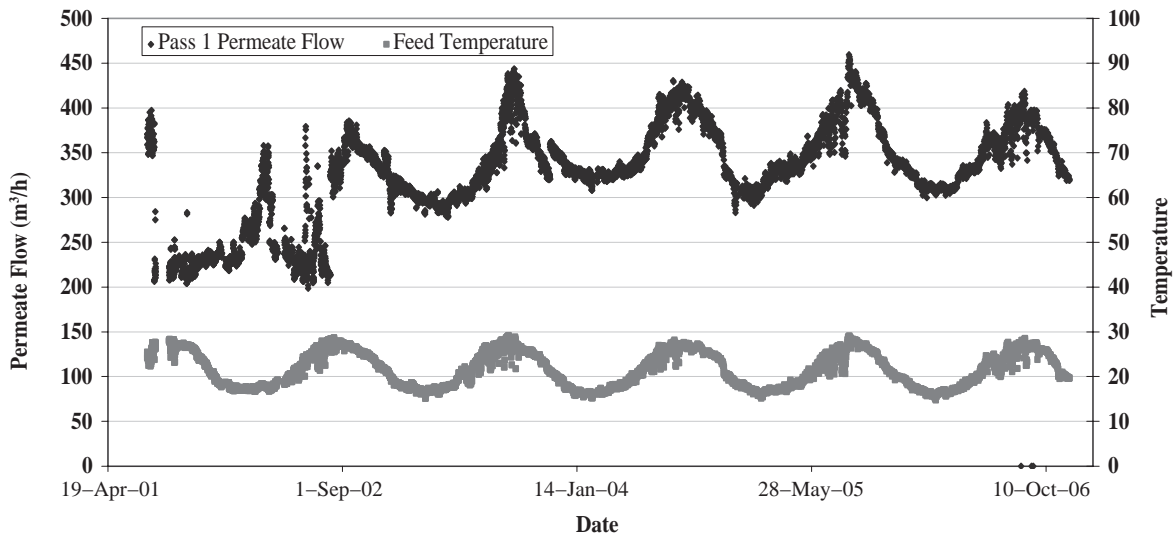

Fig. 10. Larnaca SWRO – seasonal permeate flow changes on 1st pass RO.

seawater temperature, amount of water treated by partial second pass is reduced as the permeate quality produced by 1st pass is naturally better at cold conditions. The second pass has flexibility in feed pH adjustment (pH of 7 during winter and 10 during summer period), feed flow, recovery and other parameters to adopt to seasonal conditions. For example, during the cold months the second pass permeate flow is about 230 m³/h, while during the warm months the permeate flow is 350–400 m³/h. Recently, the 2nd pass RO has been completely stopped during winter months. The SPSP design allows the plant to be continuously optimized to produce required permeate quality at the lowest possible cost (Figs. 10–12).

Larnaca SWRO plant is nice example of proper and creative use of SPSP design in order to meet strict salinity and boron regulations. Advanced process design and operation management allows plant to run with improved performance and maximize operational cost savings.

7. Conclusions

The SPSP design has proven to be cost effective and flexible design option for partial two pass RO systems. Application of SPSP design on large SWRO desalination plants helps reduce capital and operating cost

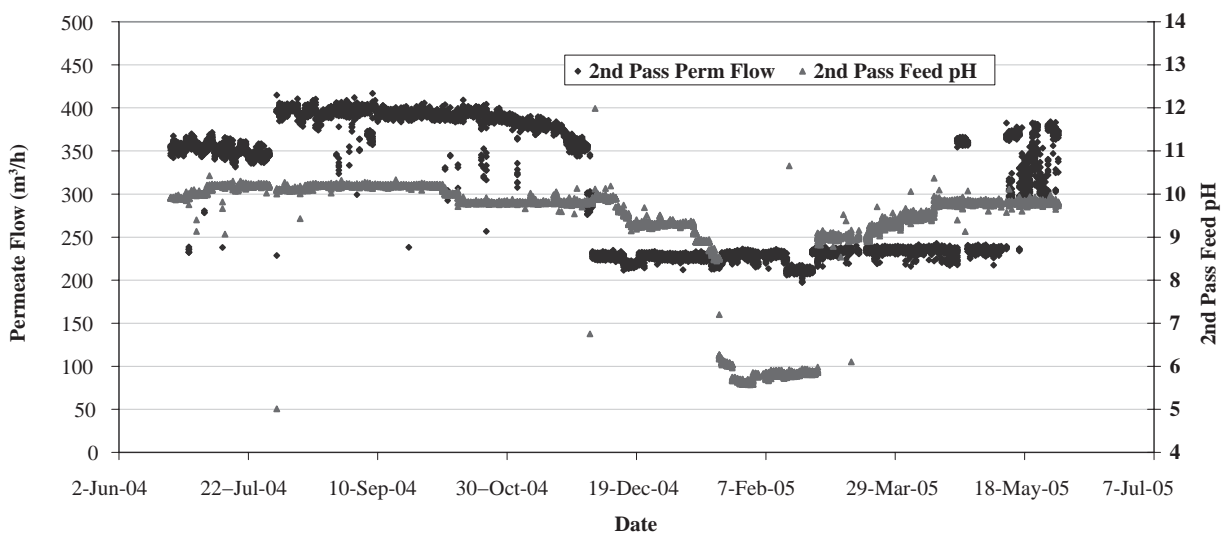

Fig. 11. Larnaca SWRO – seasonal pH adjustment and permeate flow on 2nd pass RO.

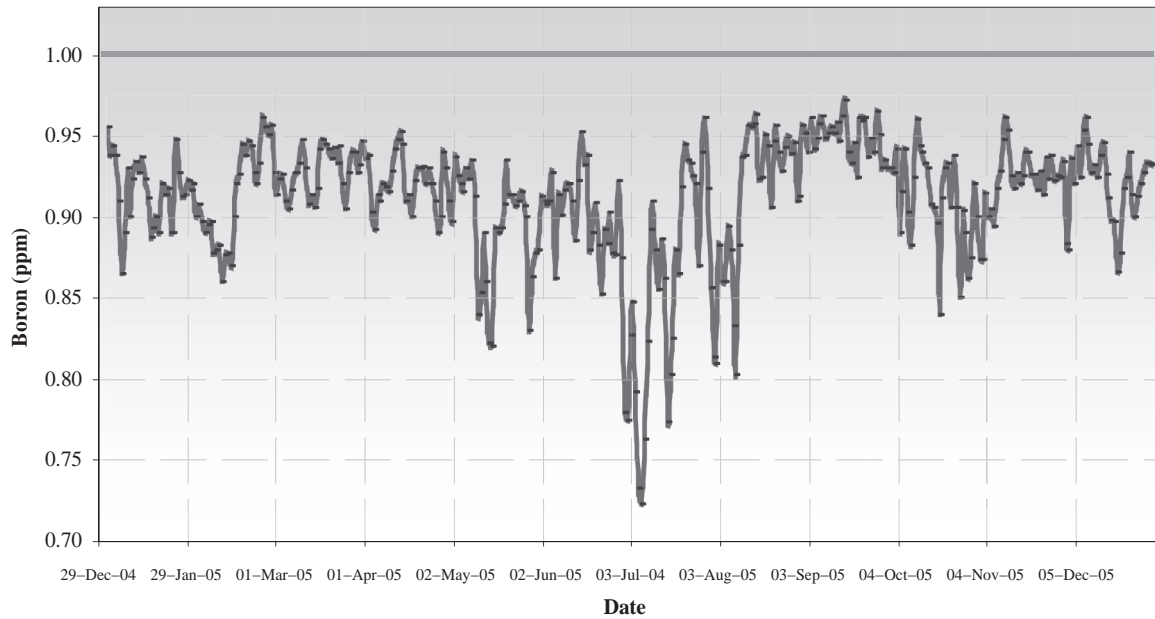

Fig. 12. Larnaca SWRO – product water Boron values during 2005.

thanks to the following advantages against conventional second pass design:

- Reduced size of pre-treatment and first pass RO flux
- Increased overall system recovery
- Smallest size of second pass RO
- Lowest energy consumption
- Lowest chemical consumption
- Lowest replacement cost
- Lowest maintenance cost

There are different engineering options for implication of SPSP design. Hydraulics long term

experience with SPSP design and operation can help to select best and most flexible engineering approach with focus on lowest capital and operating cost and continuous plant performance within design limits.

References

- [1] Donald T. Bray, U.S. Patent 4,046,685 (1977).
- [2] C. Bartels, S. Cioffi, S. Rybar, M. Wilf, E. Koutsakos, Long term experience with membrane performance at the Larnaca desalination plant, *Desalination* 221 (2008) 92-10.