



Engineering aspects of reverse osmosis module design

Jon Johnson, Markus Busch*

*Dow Water & Process Solutions, Liquid Separations Application Development Laboratory,
Industriestrasse 1, 77834 Rheinmünster, Germany
Tel. +49 7227 913 751; Fax +49 7227 913 801; email: mbusch@dow.com*

Received 14 December 2009; Accepted 3 January 2010

ABSTRACT

During the half century of development from a laboratory discovery to plants capable of producing up to half a million tons of desalinated seawater per day, reverse osmosis (RO) technology has undergone rapid transition. This transition process has caused significant transformation and consolidation in membrane chemistry, module design, and RO plant configuration and operation. From the early days, when cellulose acetate membranes were used in hollow fiber module configuration, technology has transitioned to thin film composite polyamide flat-sheet membranes in a spiral wound configuration. Early elements — about 4 inch in diameter during the early 70s — displayed flow rates approaching 250 L/h and sodium chloride rejection of about 98.5%. One of today's 16-inch diameter elements is capable of delivering 15–30 times more permeate (4000–8000 L/h) with 5–8 times less salt passage (hence a rejection rate of 99.7% or higher). This paper focuses on the transition process in RO module configuration, and how it helped to achieve these performance improvements. An introduction is provided to the two main module configurations present in the early days, hollow fiber and spiral wound and the convergence to spiral wound designs is described as well. The development and current state of the art of the spiral wound element is then reviewed in more detail, focusing on membrane properties (briefly), membrane sheet placement (sheet length and quantity), the changes in materials used (e.g. feed and permeate spacers), element size (most notably diameter), element connection systems (interconnectors versus interlocking systems). The paper concludes with some future perspectives, describing areas for further improvement.

Keywords: Thin film composite; Spiral wound; Reverse osmosis; Hollow fiber; Feed spacer; Permeate spacer; Permeate tube; Endcap; Interconnector; Interlocking endcap; Large diameter; 16 inch

1. The early history of reverse osmosis module design

Reverse osmosis module design and engineering emerged with membrane technology evolution. In order to understand module design, first membrane configuration needs to be explored, since the module design is always tailored according to the membrane characteris-

tics. There is a significant difference between membrane chemistries (most important ones being cellulose acetate and thin film composite with polyamide barrier layer), and more importantly, between the different membrane configurations (hollow fine fiber and flat sheet). Therefore, before looking into detail on the module configuration, the membrane development needs to be considered.

* Corresponding author.

1.1. The invention of RO desalination and first applications

After Schoenbein succeeded in the synthesis of nitrocellulose (1845) and Fick performed diffusion tests with nitrocellulose sheets (1855), more than 100 years had to pass before Ried and Breton succeeded in the demonstration of reverse osmosis desalination with cellulose acetate film (1959) and Loeb and Sourirajan developed asymmetric cellulose acetate membranes, which were the base for the first real world applications of reverse osmosis.

North Star, the predecessor of FilmTec, initially used cellulose tri-acetate as separating layer in a thin film composite flat sheet configuration (1964), but then switched to a polyamide barrier separating layer. The Dow Chemical Company (“Dow”) developed a cellulose tri-acetate membrane (1971) in hollow fine fiber configuration later commercialized the DOWEX™ range of HF modules (1971). Toyobo followed with a similar hollow fiber cellulose acetate membrane in 1978.

DuPont used a different membrane chemistry, initially nylon (1967), later aromatic polyamide (1969). Of the three producers of hollow fine fiber modules, the Permasep B-9 and later B-10 Permeator from DuPont became the leading element in the market in the 1980s and early 1990s.

The early cellulose acetate hollow fine fiber modules were capable of withstanding the pressures required for seawater reverse osmosis and one of the key features of

the CTA fiber was that it had a relatively high level of tolerance to the presence of free chlorine at a time when competitive HF products from DuPont and spiral wound elements from Fluid Systems had very low, effectively zero tolerance to the presence of free chlorine.

Due its market dominance in the early years of RO desalination, the Dupont Permeator is selected as typical example to illustrate the early hollow fine fiber module configuration and the performance of the initial seawater desalination systems with this concept.

1.2. The early years of RO desalination — the hollow fine fiber DuPont Permeator

The DuPont membrane was an asymmetric fiber with 42 μm inner diameter and 85 μm outer diameter, of which 0.1–1 μm was dense skin layer and remainder porous support, made from aromatic polyamide (aramide). A typical 10-inch diameter module, contained about 4,400,000 fibers. These were built into a module by applying epoxy adhesive to one side during bundling and after winding became the tube sheet. The other end of the fiber bundle was sealed with epoxy to form the nub which prevents short-circuiting of the feed stream to the brine outlet [1]. The module and RO process is shown in Fig. 1.

The first Permasep® Hollow Fiber B-10 Permeators from DuPont were introduced commercially in Europe

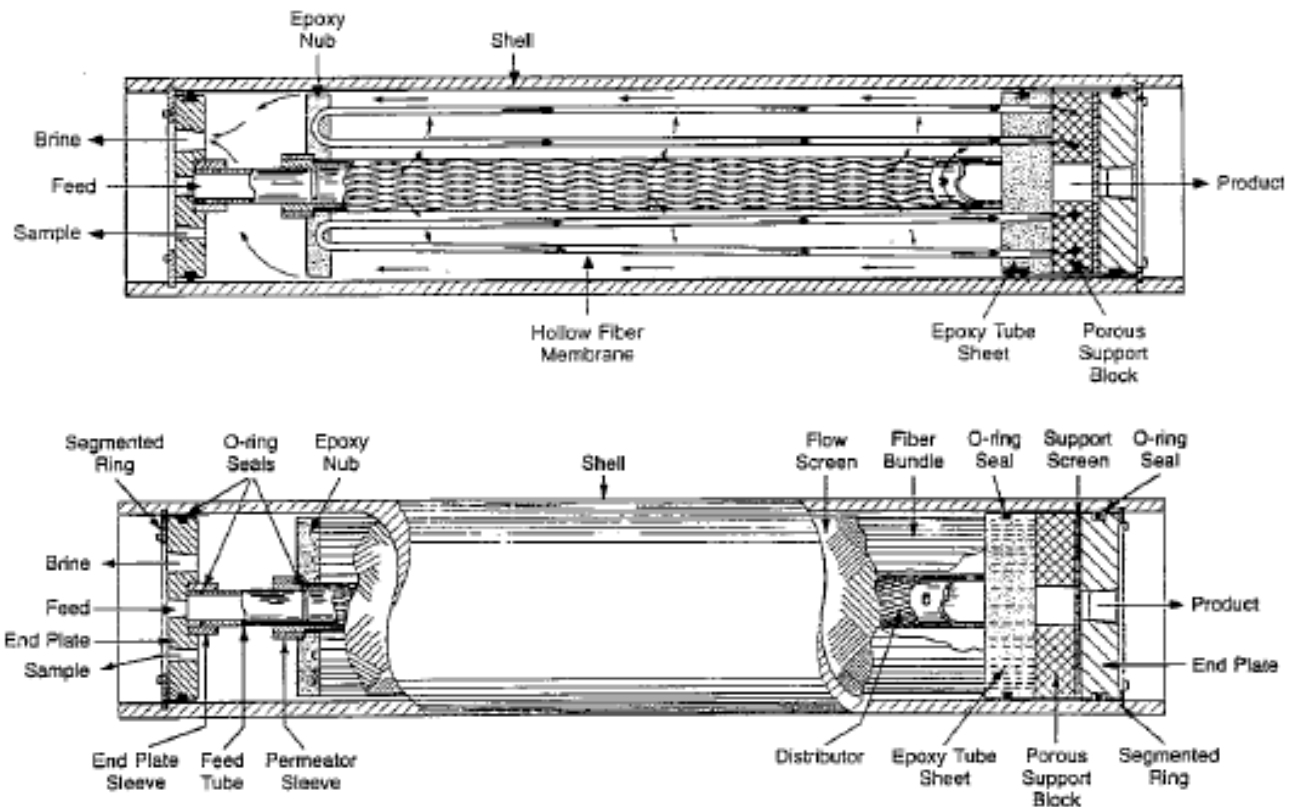

Fig. 1. Hollow fine fiber module and process [1].

in 1974. These were 4' elements which had a capacity of 5.7 m³/d (1,500 gpd) and a salt rejection of 98.5% under standard test conditions (30,000 mg/L NaCl, 55 bar/800 psi, 30% recovery, 25°C) [2].

Between 1974 and 1997 DuPont continuously improved the design and the performance of their HF elements. In 1992 the double-bundled B-10 TWIN® Permeator was introduced. The model 6880T with an aramide HF membrane had a capacity of 60.5 m³/d (16,000 gpd) and a salt rejection of 99.55% (std. cond.: 35,000 mg/L NaCl, 69 bar/1000 psi, 35% recovery, 25°C).

Shortly before DuPont terminated membrane production the Hollow-Fiber Cartridge™ was introduced. The model SW-H-8540, Single Cartridge™ had a nominal 8½-inch diameter by 40-inch length with a capacity of 30.3 m³/d (8,000 gpd) and 99.6% salt rejection (std. cond.: 35,000 mg/L NaCl, 69 bar/1000 psi, 35% recovery, 25°C) [3].

Between 1983 and 1997, for a typical seawater with a temperature between 17–38°C and a salt content of 36,000–45,000 mg/L, the major design characteristics of a single pass Permasep SWRO (seawater reverse osmosis) plant with a B10-Permeator were [4–8]:

- Recovery: 30–50%
- Feed pressure: 1,000–1,200 psi (69–82.7 bar)
- Permeate quality: < 500 mg/L
- Energy consumption: 3.7–8.2 kWh/m³

1.3. The shift to spiral wound modules

At the time when Permasep HF-Permeators for desalination of seawater were introduced into the market in the 1970's they had some advantages compared to seawater spiral wound elements which explain their success in the RO-market at this time [9].

Permasep HF-Permeators are self supporting membranes. This simplified the hardware for fabrication compared to flat-sheet membranes which have to be assembled with spacers and supports. In addition the hollow fibers were able to operate up to 82.7 bar (1,200 psi), which allowed to reach relatively high recoveries, like 60% at 25°C and 38,000 mg/L feed TDS (total dissolved solids).

At a similar specific permeate flux (flow per membrane area), a conventional flat sheet membrane needed only about 50% of the feed pressure of a hollow fiber. This relatively low permeability of a single fiber in comparison to a flat sheet membrane was compensated by the Permasep HF Permeator with the extremely high area per Permeator (Single Cartridge™: >372 m², (4,000 ft²)).

This high area allowed working at relatively low fluxes. This reduces concentration polarization and the risk of scaling. The relatively low concentration polarization also improved the rejection of the Permeator.

A major disadvantage of the Permasep HF Permeator was its tendency to foul and plug due to low free space

between the hollow fibers and due to dead zones in the Permeator [9].

In addition fouling and scaling was difficult to remove due to the low cross flow velocities and a relatively limited pH-range (4–11). These constraints required a high RO-feed water quality (SDI <3) which resulted in higher pretreatment costs and some operational difficulties.

To keep the rejection of the Permasep HF Permeator constant it generally had to be coated by PT-A (poly vinyl methyl ether) and PT-B (tannic acid) [9]. These chemicals had to be reapplied frequently, PT-B even after every membrane cleaning cycle.

1.4. The exit of hollow fine fiber modules

Notwithstanding the benefits of chlorine tolerance of the DOWEX cellulose triacetate fiber, Dow gradually became aware of other limitations and short comings of both the CTA chemistry and the hollow fiber module construction.

To address these issues Dow purchased the FilmTec Corporation, in 1985 and thus gained access to polyamide, thin film Composite, flat sheet membrane technology and also to spiral wound element construction, and exited the hollow fine fiber market.

The DuPont hollow fiber, which had been leading the RO market in the 1980s and early 1990s, started to lose ground to polyamide spiral wound modules in the 1990s. This was due to the increasingly fierce competition of a larger quantity of spiral wound module suppliers such as FilmTec/Dow, Rohm & Haas/Hydranautics, Toray, Fluid Systems/Koch, TriSep and Osmonics/General Electric, which significantly reduced module pricing and advanced module concepts. The DuPont concept lost its appeal and the business became increasingly unattractive, which led to the exit of DuPont from hollow fine fiber module production.

In most parts of the world, plants have converted from hollow fine fiber module use to spiral wound modules. Prominent examples for seawater plants are Galilah (United Arab Emirates), Agip Gela (Italy) and Agragua Gran Canaria (Spain) [10–12]. Significant cost savings have been achieved by retrofitting plants from hollow fine fiber to spiral wound modules [10].

In Saudi Arabia there are still various large old plants using hollow fine fiber modules, e.g. Al Jubail, Al Birk, Jeddah, Haqel, Duba and Yanbo and even new plants have been added recently (Shuqeiqh, Jeddah). Toyobo is the only remaining hollow fine fiber supplier, and enjoys an attractive single supplier situation in these projects.

1.5. The future of spiral wound modules

In the past 20 years considerable improvement of seawater spiral wound elements have been made. The capacity of an 8-inch element has been doubled whereas the salt passage is about three times less [13,14]. This

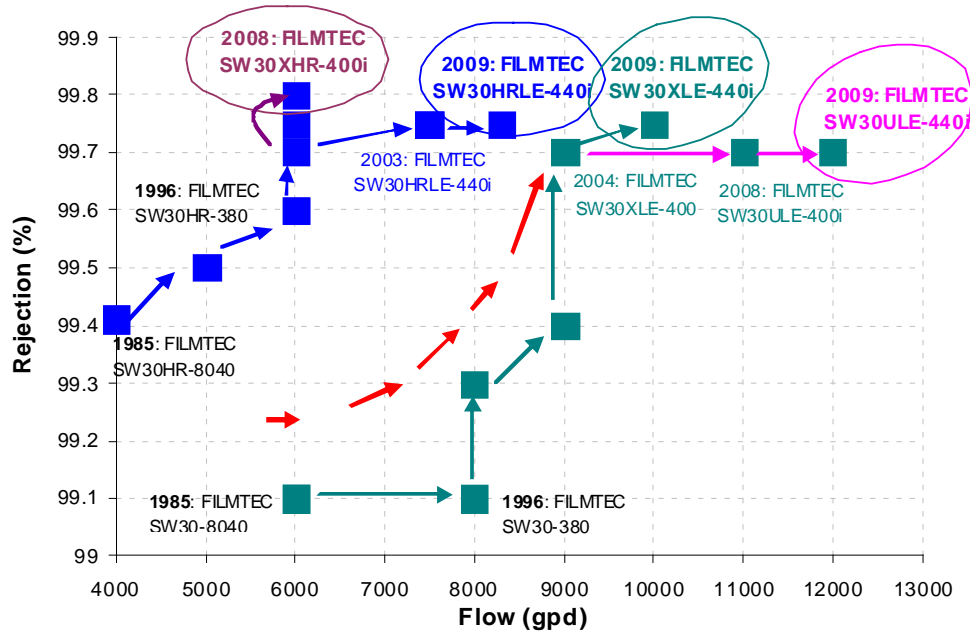

Fig. 2. Evolution of spiral wound module performance, illustrated by example of the DOW™ FILMTEC™ seawater desalination product range.

development is illustrated in Fig. 2 at the example of the DOW™ FILMTEC™ seawater reverse osmosis range.

It has been possible to increase the active area in an 8-inch module from 300 ft² in the early days (1980s) to 440 ft² and further increases are possible. These increases are possible while feed spacer thickness is maintained and geometry improved. The development of elements with larger diameter (16-inch) allows a factor 4.3 increase in the membrane area, to 1725 ft², and by this allows significant savings.

Furthermore the maximum operating pressure for spiral wound elements was 69 bar (1,000 psi) in the past. Recent improvements in membrane stability and permeate spacer technology of some manufacturers increased the maximum pressure to 82.7 bar (1,200 psi) [15–18]. This allows working at a relatively high osmotic pressure and thus increasing the recovery for spiral wound elements up to 60% and more. Improved rejection of the membranes compensates the higher system salt passage which goes along with a higher system recovery.

There is also ongoing work with regards to the product water tubes and the element connection system has been significantly improved by the introduction of interlocking end caps.

Recent achievements as well as continued development of spiral wound module design is contributing to significant cost savings in RO technology and offers to make this technology even more widely available for sustainable and affordable water production in many parts of the world.

Therefore, the remainder of this paper will focus exclusively on selected engineering aspects of the spiral wound module, as developed for the purpose of treating water through reverse osmosis.

The discussion will emphasize the module configurations used in large-scale municipal and industrial RO systems — those with diameters of at least 8 inch. The patent documents and technical papers mentioned in connection with specific topics are by no means exhaustive, but are intended to be illustrative of the work that has occurred. The documents usually include a useful list of references for those interested in retrieving additional information.

2. Current status and future direction of spiral-wound module components and engineering

Despite its cylindrical configuration, the spiral-wound reverse osmosis module is essentially a flat-sheet, cross flow device. The feed water passes through the module axially, while permeate moves in the spiral, radial direction toward the permeate collection tube. The membrane interposed between these streams remains the technological centerpiece of the module, but other aspects of module engineering are increasingly critical to performance.

The increased focus on module engineering is driven in part by the desire for cost reduction, but more often by the desire to extract the full value of the latest membrane technologies. The promised membrane benefits can only be fully realized when module designs focus on energy efficiency and the preservation of membrane salt rejection.

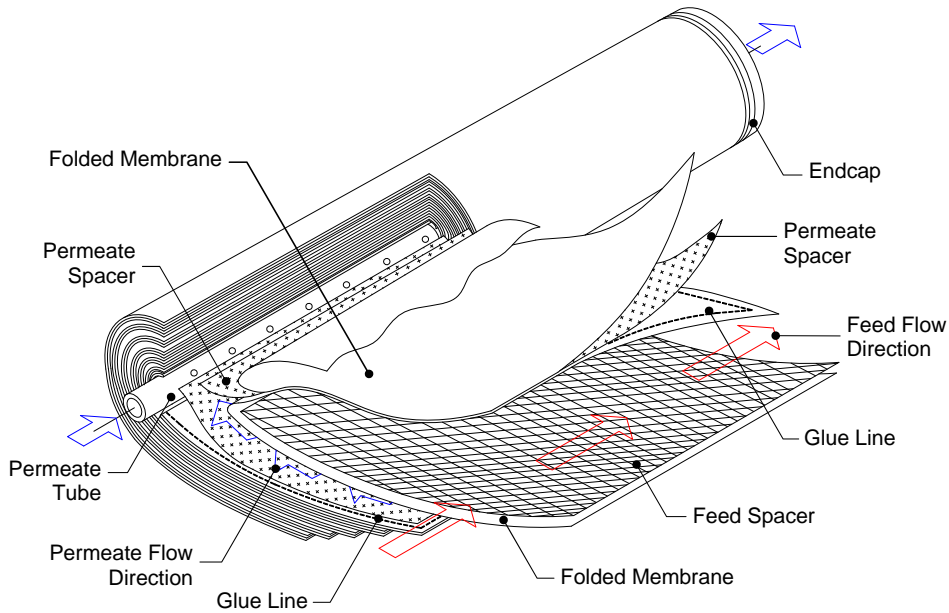

Fig. 3. Configuration of spiral wound membrane module for reverse osmosis.

The following discussion is organized around the five major non-membrane components of the spiral wound module:

- Feed spacer
- Permeate spacer
- Permeate tube
- Endcap

These key components are depicted in Fig. 3. These components will be considered in turn, with a brief overview of the role and importance of each, followed by a discussion of recent developments.

2.1. Feed spacer

By far the most common feed spacer configuration used in reverse osmosis membrane modules is the biplanar extruded net (Fig. 4a).

One of the earliest patents for making the net was obtained by Nalle [19], who described counter-rotating die which produced a continuous, cylindrical mesh structure that was stretched over a mandrel, quenched, and then slit to create a flat web (Fig. 4b).

Most RO feed spacers are made from polypropylene, which offers the preferred combination of extrudability,

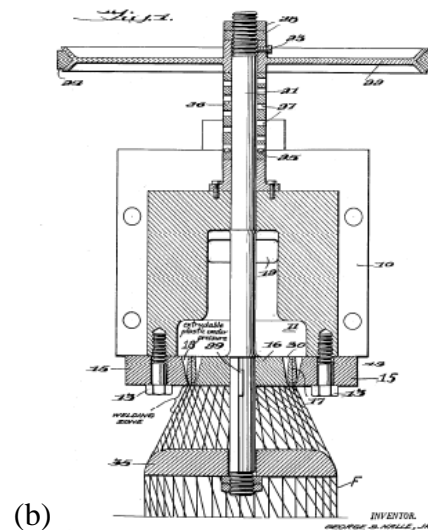
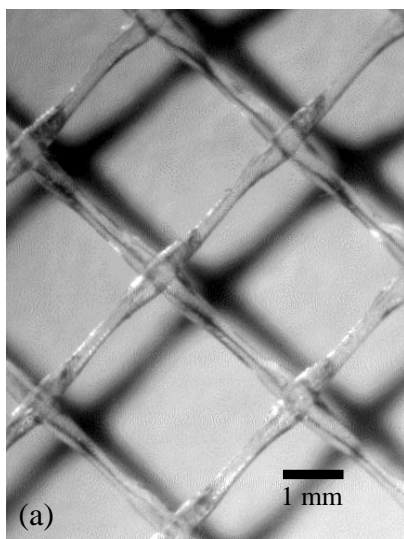

Fig. 4. (a) Biplanar extruded netting is comprised of two intersecting sets of parallel, extruded strands; (b) An early patent was obtained by Nalle [19].

low cost, and chemical inertness. Thicknesses between 0.6 and 0.9 mm are typical. The spacer is priced below US\$1.00/m² for the most commonly used varieties.

2.1.1. Purpose of the feed spacer

The feed spacer has two functions. It provides an open channel for the flowing feed water by maintaining separation between the membrane sheets. It also promotes mixing within the feed channel, moving salt and other rejected substances away from the membrane surface.

2.1.1.1. Maintaining an open feed channel

A key step in the fabrication of spiral-wound membrane modules is the rolling-up of the layered membrane and spacer materials around the permeate tube. The compressive forces generated during roll-up, and the consequent tightening of the spiral, cause compression of the feed spacer and nesting of adjacent feed spacer layers.

An apparent change in thickness may be estimated from the original thickness of the spacer, obtained from a representative sample using a caliper, and the apparent thickness of the feed channel, measured after module fabrication:

$$\begin{aligned} \text{Change in thickness} \\ = \frac{\text{Spacer thickness} - \text{Channel thickness}}{\text{Spacer thickness}} \times 100\% \end{aligned} \quad (1)$$

The apparent channel thickness is estimated by measuring the body diameter of the fabricated module and the thicknesses and lengths (in the spiral direction) of all of the internal materials of construction. The materials are non-nesting and negligibly compressible, except for the feed spacer, which allows the apparent channel thickness to be obtained mathematically.

The net-type feed spacers used in RO modules provide points of contact with the membrane that support and maintain the open feed channel. As shown in Fig. 4a, these points are formed by the intersection of the polymer

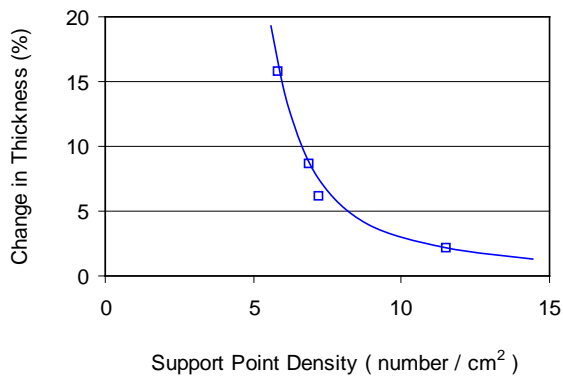

Fig. 5. Effect of support point density upon change in apparent thickness of feed spacer during module fabrication.

strands. The importance of support point density is illustrated in Fig. 5, where the change in channel thickness was plotted against the support point density, in points per square centimeter, for a variety of different spacers. RO modules were made from each spacer under identical fabrication conditions, and the change in thickness was determined as outlined above.

The trend in Fig. 5 illustrates a significant constraint upon feed spacer optimization. Biplanar extruded nets cannot be so reconfigured that their ability to support and separate the membrane layers is compromised. This can occur if the number of intersections is dramatically reduced. Support point densities of 10–12 per 1 cm² are typical of commercially available spacers for large-scale applications.

2.1.1.2. Mixing the feed water

The spacer mixing effectiveness, or more precisely the mass transfer effectiveness, is expressed in terms of the concentration polarization of a given specie, usually a dissolved salt, that is partially or entirely rejected by the membrane. The polarization factor, Γ , is defined as follows:

$$\Gamma = \frac{C_{\text{membrane}}}{C_{\text{bulk}}} \quad (2)$$

where C_{membrane} is the specie concentration at the membrane surface, and C_{bulk} is the flow-weighted average concentration for the channel cross-section. Γ depends upon the local permeate flux, the mass diffusivity of the specie of interest, the degree of rejection, and the extent of mass transfer.

For sodium chloride, conventional spacers and typical operating conditions provide average Γ in the range of 1.05–1.15. The osmotic barrier in many reverse osmosis applications is therefore increased by 5–15% due to imperfect feed channel mixing. This increases by up to 10% the direct energy consumption in seawater desalination. Feed spacers which reduce concentration polarization have been proposed, but significant improvement among known configurations leads to increased feed channel pressure drop.

2.1.2. The pressure drop tradeoff

An unwanted byproduct of the mechanical support and mass transfer functions is feed channel pressure drop. Because RO modules are typically employed several-in-series within large systems, feed-side pressure drop impacts system performance by reducing the trans-membrane pressure, and consequently the permeate production, in the downstream modules. This under-utilization leads to over-utilization and increased rate of fouling in the upstream modules.

Efforts to improve mass transfer through optimization

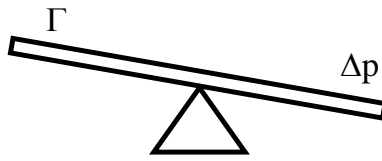

Fig. 6. The tradeoff between concentration polarization, Γ , and feed-side pressure drop, Δp , constrains feed spacer optimization.

of the biplanar extruded net and other configurations have not resulted in dramatic changes to commercial spacers, which remain much the same as those used 20 years ago. Reasons for this include the relatively small magnitude of the potential benefit associated with improved mass transfer compared to that achieved historically through ongoing improvements in membrane chemistry. A second reason is the mass transfer tradeoff depicted in Fig. 6, which ties reduced polarization to increased pressure drop. A third reason is the low cost of existing spacers.

The tradeoff is not immovable, and spacers have been proposed which promise simultaneous mass transfer and pressure drop improvement. For example, multi-layer spacers [20,21] place obstructions at the membrane surface where they can effectively interrupt the concentration boundary layer while minimizing disturbance of the bulk flow.

Spacers with strands of non-circular cross section appear to reduce pressure drop while still mixing the boundary layer [22,23]. Unfortunately, economical large-scale manufacturing methods for such configurations have not been developed.

2.1.3. Feed spacers and fouling

In addition to the osmotic penalty, imperfect mixing reduces salt rejection, promotes scaling at the membrane surface, and increases the rate of deposition of certain foulants. Fouling mitigation may represent the most significant opportunity for operational savings through improved feed spacer design. However, the magnitude of the potential improvement and the means by which spacers can reduce fouling through improved hydrodynamics are not yet well understood. Examples of recent spacer research include investigations of biofouling [24] and particulate fouling [25]. There appears to be less focus on the impact of spacers on other forms of fouling, such as colloidal and adsorptive organic fouling.

2.1.4. Current status and future directions

Recent spacer development for commercial use has focused primarily on pressure drop reduction [26–28]. This has been shown to reduce energy consumption, improve hydraulic balance in low-pressure RO systems,

and lengthen the time between cleanings in applications where excessive feed-side pressure drop is the criterion by which cleaning intervals are determined.

Anti-microbial spacers are of interest. Feed spacers containing silver [29] and copper [30] have been formulated. A spacer which varies in thickness along the length of the module has been proposed for improved hydrodynamic performance [31]. The spacer can be eliminated entirely if membrane-supporting structures are applied directly to the membrane surface [32].

Future feed spacer development, in both fundamental research and product improvement, is expected to emphasize fouling performance, including protocols for measuring and comparing rates of fouling among spacers. The tradeoff between mass transfer and pressure drop will remain at the forefront. Configurations will be presented that skew to one side of the tradeoff for the benefit of specific applications.

2.2. Permeate spacer

The permeate spacer provides a conduit for the collection and transport of permeate from the membrane to the permeate tube. Woven polyester fabric is the most common spacer in commercial use. The tricot weave is often chosen for its structural rigidity, smoothness, and fluid-channeling characteristics. The tricot is sandwiched between two sheets of membrane and sealed on three edges by glue, as shown in Fig. 1, to create an envelope that is often referred to as a membrane *leaf*.

Pressure drop in the permeate spacer has a profound effect upon module performance. The effect is detrimental in two respects.

First, the net driving pressure required to obtain the desired permeate flow is increased. In other words, the *element efficiency* is reduced. The element efficiency, ε , is the ratio of the actual permeate flow, Q , to the expected output based upon the active membrane area, A , the membrane permeability, P , and the net driving pressure, NDP:

$$\varepsilon = \frac{Q}{A \cdot P \cdot \text{NDP}} \quad (3)$$

Second, for a given average flux within the element, the range of variation of the local flux is increased. Near the root of the leaf, close to the permeate tube, the flux is higher. Further from the tube, near the tip of the leaf, the flux is lower. Consequently, the membrane furthest from the tube may be underutilized, while the membrane close to the tube may be subject to premature fouling. The smallest possible range of variation is desired.

2.2.1. Permeate spacer pressure drop

The pressure drop within the spacer is very nearly linear with flow rate, and may be parameterized using the following simple relationship:

$$\frac{dp}{dx} = -k \cdot \frac{q}{w} \tag{4}$$

where dp/dx is the pressure drop in the permeate flow direction at a given distance from the collection tube, q is the volumetric flow rate moving through the spacer at that location, w is the width of the leaf measured parallel to the permeate tube, and k is the friction parameter for the spacer. There is a slight variation of k with applied pressure due to the squeezing of the woven structure.

2.2.2. Element efficiency

The efficiency is readily estimated from standard

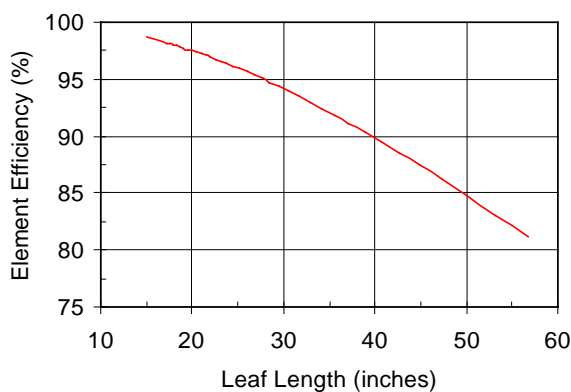

Fig. 7. Effect of leaf length upon element efficiency $P = 0.05$ gfd/psi, $k = 130$ psi-s/in³.

mathematical models [33]. A curve relating leaf length to element efficiency was calculated and plotted in Fig. 7 using a friction parameter, k , of 130 psi-s/in³, and membrane permeability, P , of 0.05 gfd/psi. This permeability is and spacer performance is representative of commercial seawater RO modules.

2.2.3. Local flux distribution

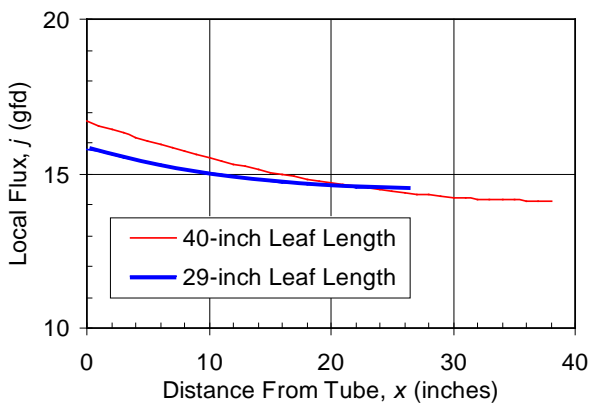

Fig. 8. Variation in local membrane flux with leaf coordinate (distance from permeate collection tube) $P = 0.05$ gfd/psi, $k = 130$ psi-s/in³, $j_{avg} = 15$ gfd.

Using the available mathematical models, a comparison was made between two membrane leaves, one 29-inch long and one 40-inch long. The net driving pressures were chosen to provide the same average flux in the two leaves. The local flux was then plotted as a function of the coordinate, x , in Fig. 8.

The local flux is seen to vary from 14.5 to 16 gfd within the shorter leaf, and from 14 to 17 gfd within the longer leaf. Both of these hypothetical leaves were designed and operated to provide an average flux of 15 gfd, but the range of variation was twice as large for the longer leaf.

2.2.4. Future directions

Due to the pressure drop imposed by woven permeate spacer materials, shorter membrane leaves in spiral-wound module construction provide higher module efficiency and reduced flux variation. Development efforts by membrane manufacturers will continue to accommodate current permeate spacers by focusing on increased use of automation, which enables defect-free fabrication of modules with more, shorter leaves.

Consequently, improved permeate spacers represent untapped value. They have the potential to increase module efficiency or, if leaf counts reduced and fabrication times shortened, to reduce membrane module cost. The challenge for future developers will be to reduce pressure drop and maintain or improve resistance to deformation by RO feed pressures. This must be done at very low cost, as woven polyester tricot for RO is typically priced below US \$5.00/m².

2.2.5. Forward osmosis

Permeate spacers for forward osmosis applications will require even greater strides in pressure drop reduction. The presence of a sweep stream on the permeate side of the membrane will drive consideration of a permeate channel that more closely resembles the feed channel in terms of its mass transfer and pressure drop characteristics [34].

2.3. Permeate tube

The permeate tube collects permeate from the spacer materials inside a module. In multi-module pressure vessels, the tubes are connected in series, and serve as a conduit for the transport of permeate to an external manifold. The permeate tube also provides important diagnostic access during operation, permitting conductivity sensors and sampling probes to be inserted in search of membrane defects and leakage.

Tube configurations have been largely unchanged in 20 years of RO module development, although materials and methods of tube fabrication have been updated. Tubes for standard modules of 40-inch length are usually extruded. Secondary machining operations add

side-holes and tightly-toleranced sealing surfaces. Tubes for shorter modules are sometimes injection-molded. Although most tubes for 8-inch diameter modules have inside diameters near 2.5 cm, a large-diameter tube has been offered in commercially available low-energy brackish water and nanofiltration elements [35]. The 3.5 cm inside diameter reduces pressure drop, which is a significant contributor to unwanted permeate backpressure in low-pressure RO systems.

2.3.1. Future directions

Future designs will likely make further use of the tube for collecting and relaying information. Probes located inside the tube and communicating via radio frequency with the outside world have been described [36]. Additional features that work cooperatively with probes and sensors to ease the collection of performance data pertaining to individual elements within a vessel are needed.

Finally, the loading and unloading of pressure vessels may one day make use of mechanized module handling equipment. Such equipment could use the permeate tube for gripping and lifting, much like the mechanized spool handlers used in other industrial applications. Features that aid element handling are envisioned.

2.4. Endcap

The past five years have witnessed renewed focus on endcap design and functionality. The endcap is a highly engineered, injection-molded plastic component that plays several important roles within the module. Here is a partial list of those roles:

- Leaf retention — The endcap prevents telescoping (relative axial movement) of the membrane leaves, and is sometimes referred to as an *anti-telescoping device* (ATD).
- Load transmission — The endcaps transmit axial load from module to module and also into the rigid fiberglass shell of the module.

- Bypass prevention — The endcap holds a brine seal, which prevents feed water from bypassing the module by entering the annulus between the module and inside wall of the pressure vessel. The connection between fiberglass shell and endcap helps to prevent bypass around the brine seal.
- Permeate connection — In some cases, the endcap has been designed to include features for interlocking and permeate sealing between modules.

2.4.1. Recent developments

Changes to commercially-available endcaps include the recent addition of recessed areas in the endcap face, designed to permit easier venting of the annulus between the rigid external shell of the module and the inside wall of the vessel [26]. The connection between the endcap and the rigid external shell of the module is an area of ongoing optimization [37]. Features for improved mass transfer within the feed channel of the spiral-wound module based upon special endcap configurations have been claimed [38].

2.4.2. Interlocking endcaps

For more than 20 years, sliding couplers like that shown in Fig. 9a have been used by the industry to join the permeate tubes of adjacent spiral wound membrane modules contained in pressure vessels. Although there are slight variations in the coupler designs offered by membrane suppliers, all are based on the same principal — a pipe segment with radially compressed o-rings at both ends, internally or externally connected to the adjacent permeate tubes.

The keys to best possible performance for standard couplers are lubrication and proper loading technique. Problems occurring under less-than-ideal conditions include: rolled or twisted o-rings during element installation into pressure vessels, energy-consuming flow

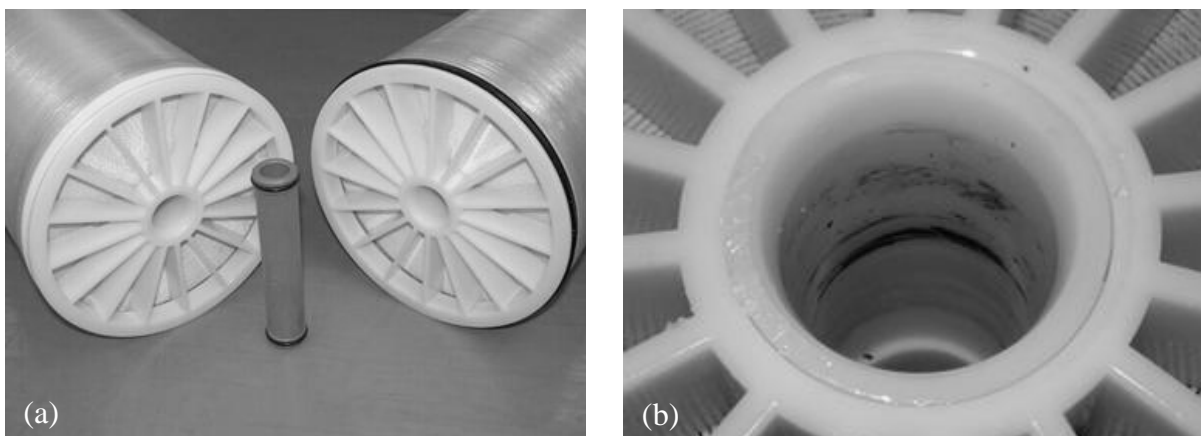

Fig. 9. (a) Standard sliding coupler used to connect the permeate tubes of adjacent elements; (b) Residue from o-ring abrasion.

resistance caused by the reduced inside diameter of the coupler, and o-ring abrasion and subsequent leakage due to excessive movement of the coupler relative to the permeate tube during operation and cleaning. Evidence of o-ring abrasion inside a permeate tube, like that shown in Fig. 8, is indicative of a failed or soon-to-fail permeate seal.

For improved robustness and to remove sliding coupler concerns entirely, the configuration shown in Fig. 10 was developed. The sealing functions of the coupler were transferred to the endcap in the form of a conventional o-ring face seal [39]. The rotational locking of the elements provides compression of the permeate face seal, eliminating the possibility of improper coupler installation and subsequent seal abrasion.

An older design combines a sliding coupler with a method of interlocking adjacent modules [40]. This prevents most of the relative movement that causes o-ring abrasion. A variation on this approach requires insertion of small, insertable “keepers” to interlock adjacent elements [41].

2.4.2. Future directions

Like permeate tubes, endcaps are likely to include features that enhance element handling, perhaps by interfacing with machines designed to help load elements into very large RO systems.

Methods of constructing and coupling modules which eliminate the need for pressure vessels have been proposed, as depicted in Fig. 11 [42]. These may gain traction for lower-pressure applications.

3. Future direction of the spiral wound module – large-diameter module formats

The overwhelming majority of large-scale RO systems using spiral-wound modules rely upon the industry-stan-

dard 8-inch diameter by 40-inch long module configuration. In view of the scale of recent installations — with individual sites sometimes incorporating thousands of pressure vessels and tens of thousands of modules — strategies for improving upon the economy of scale the 8-inch format received renewed attention.

3.1. Historical background

Modules larger than 8 inch in diameter have long been in operation [43], and past studies have shown that large diameter modules enable significant reductions in reverse osmosis plant capital cost compared to conventional 8-inch systems [44]. Nevertheless, market acceptance of larger diameters has been slow.

In 2003, a consortium was assembled to address the lack of competition and customer choice within the larger format, which was seen a barrier to the widespread use of larger elements. The consortium, partially funded by the US Bureau of Reclamation, was charged with the task of selecting a single diameter to serve as a platform for standardization and competition among the membrane manufacturers. Economic studies were conducted by the independent consulting firm of CH2MHill.

The consortium selected 16 inches as the standard diameter for the large format. Overall construction cost savings of up to 24% for a groundwater RO plant with minimal pretreatment, and up to 11% for an open-intake seawater desalination plant, were projected. The detailed assumptions and methodology supporting the economic projections have been published [45].

This study motivated the introduction of 16-inch membrane products by several membrane manufacturers. Large diameter RO modules, including 16-inch, are now in permanent or pilot operation at more than twenty sites worldwide [46]. A detailed review of one manufacturer’s

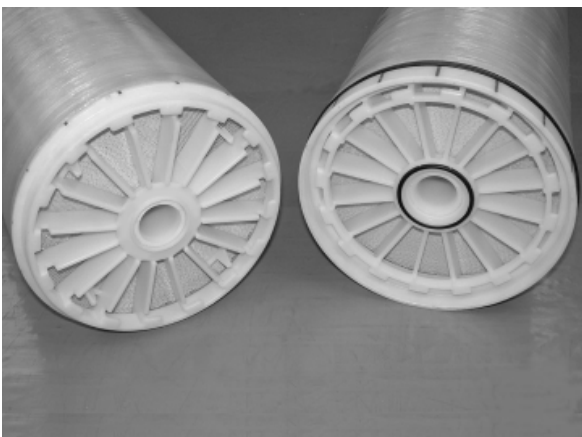

Fig. 10. Interlocking endcaps.

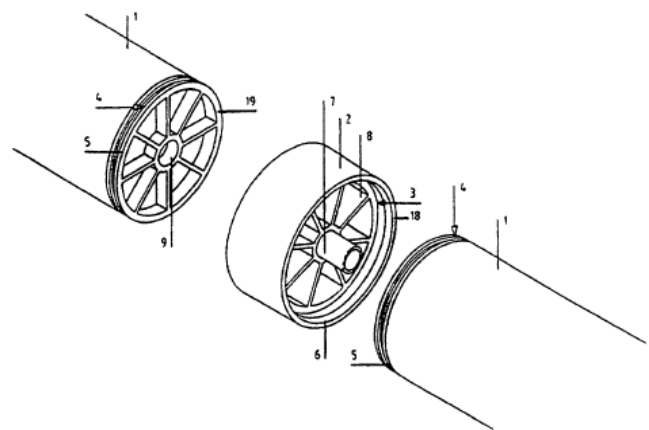

Fig. 11. Method of interconnection which eliminates the pressure vessel.

approach to 16-inch component engineering and overall element design was presented by Hallan et al. [47].

3.2. Train size

Savings projected by the consortium consultant were based upon the need for fewer RO trains when using larger diameters. The *train* is the building block of very large RO systems. It is a collection of vessels that are plumbed, controlled, and instrumented to work as a whole. In a large plant, a train may be taken off-line for maintenance purposes while other trains continue to run.

Faigon and Liberman [48] argued that very large trains have lower availability than smaller trains due to frequent maintenance to repair o-ring leaks. Conversely, very small trains are more expensive to construct due to piping, instrumentation, control, and footprint costs. They proposed 90 vessels as an economic optimum. In its modeling on behalf of the consortium, CH2MHill did not permit the large-diameter train to exceed 90 vessels. Even though the 8-inch trains were permitted more vessels in some cases, large diameter systems could still be built with fewer trains, substantially reducing costs related to piping, instrumentation, control, and footprint.

The availability argument has shifted even further than the consortium study would suggest. Sixteen-inch

elements are now available with interlocking endcaps and just one permeate o-ring per connection [47]. In Fig. 12, the number of permeate seals is contrasted for 8-inch and interlocking 16-inch systems. Combined with the increased reliability of the interlocking, non-sliding seal configuration, the 16-inch element removes o-ring leakage from the train sizing discussion.

3.3. Large-diameter performance

Early reports on the performance of large-diameter elements cited reduced element efficiency and increased rates of fouling compared to 8-inch [49]. Recent long-term operating results show that engineering development efforts have successfully addressed these concerns.

The following operational data pertain to 8 and 16-inch RO systems that were run in parallel at Bedok NEWater Factory, Singapore.

Both systems were comprised of conventional two-by-one arrays of seven-module pressure vessels. Modules were 40 inch long in all cases. Both systems were operated at 75% permeate recovery and 20.5 l/mh average flux. The 16-inch modules had 4.3 times more active area than the 8-inch, and consequently the 16-inch system was run so as to produce 4.3 times more permeate.

As shown above, the feed pressures were the same over six months of operation, except during a March–April excursion attributable to unequal operation. Fig. 13 confirms equal module efficiency and equivalent rates of fouling and cleanability [50].

3.4. Future directions

Large-diameter element designs are unlikely to change significantly in the near term because current configurations reflect multi-year engineering development programs only recently completed by the major membrane manufacturers. To grow the 16-inch market, further open discussion of the factors governing the maximum train size, the magnitude of the savings from

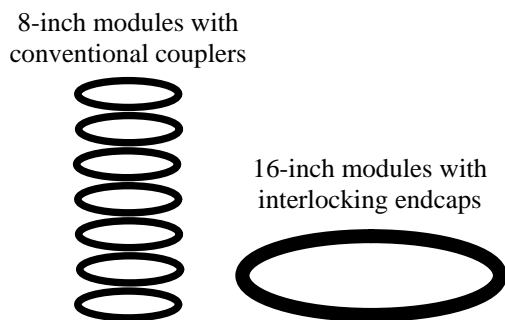

Fig. 12. Comparing 8-inch to 16-inch, the o-ring ratio is 7 to 1.

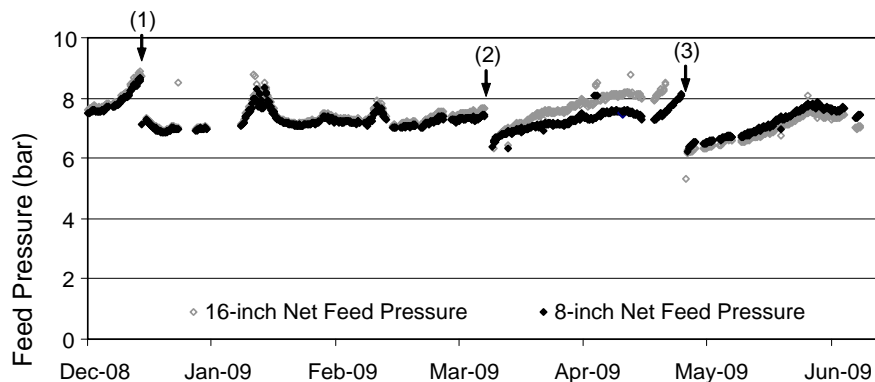

Fig. 13. Comparison of net feed pressure for 8-inch and 16-inch systems operated at 20.5 l/mh. Chemical cleaning of both trains was performed at (1,2,3).

building fewer trains, and the overall economy of scale enabled by 16-inch elements is needed.

While a number of options for 16-inch handling have been devised and implemented [50,51] the size and weight of 16-inch elements remains a perceived obstacle in some cases. Continued engineering development of loading and unloading tools is expected, and should ultimately result in options that are safer and more efficient than manual 8-inch handling.

4. Summary and conclusions

During the half century of development from a laboratory discovery to plants capable of producing up to half a million daily tons of desalinated seawater, reverse osmosis (RO) technology has undergone rapid transition. This transition process has caused significant transformation and consolidation in membrane chemistry, module design, and RO plant configuration and operation.

From the early days, when cellulose acetate membranes were used in hollow fiber module configuration, technology has transitioned to thin film composite polyamide flat-sheet membranes in spiral wound configuration.

Early elements — about 4-inch in diameter during the early 1970s — displayed flow rates of approximately 250 L/h and sodium chloride rejection of about 98.5%. One of today's 16-inch diameter elements is capable of delivering 15–30 times more permeate (4000–8000 L/h) with five to eight times less salt passage (hence a rejection rate of 99.7% or higher).

This paper focuses on the transition process in RO module configuration, and how this transformation helped to achieve the above described performance improvements. It can be seen how the development of thin film composite membranes and spiral wound element configurations helped achieving larger rejection and higher productivity which resulted in better water quality significantly lower energy consumption, and improved system operation (lower fouling, higher recovery)

The review of various spiral wound component and engineering aspects shows the following:

- Feed spacers play a critical role in trading off membrane support and feed mixing, hence in providing low energy, low fouling and high membrane area density in the vessel. However, despite considerable R&D investment, have undergone little change since the early production principles.
- Permeate spacer and leaf (length) design play a critical role in element efficiency (hence sustainable productivity) as well as in fouling behavior (flux distribution). Optimization potential remains.
- The product water tube has been hydraulically been optimized, but more improvements (sensing/probing, grips supporting loading/unloading) are possible and are being explored

- The connection system between RO elements has been optimized and some disadvantages of sliding couplers (abrasion, stress) have been eliminated by interlocking end caps
- Multi-year efforts to develop 16-inch modules have been completed, and these provide potential to improve plant design and economics, however issues with regards to system engineering (e.g. train size) and element loading still need to be addressed.

Overall, significant improvements have been made in the above described areas, which have had a very positive effect in reducing cost of water from RO technology. However, it can be seen that some recent developments, e.g. 16 inch, provide potential that has rarely been tapped yet. There is also more development possible in several areas, e.g. spacers.

References

- [1] Dupont Company, Permasep Technical Information Manual, Wilmington, 1983.
- [2] M. Cirera and C.P. Shields, History, success and recent developments in seawater reverse osmosis desalting in Spain — using DuPont reverse osmosis technology, Proc. IDA World Congress on Desalination and Water Reuse, Madrid, 1997, 2 (1997) 421–439.
- [3] T.J. Eckman, C.P. Shields, J.W. Stranz and J.M. Wright III, The Hollow-Fiber Cartridge™ development and commercialization of an entirely new reverse osmosis device/technology, Proc. IDA World Congress on Desalination and Water Reuse, Madrid, 1997, 3 (1997) 441–458.
- [4] W.T. Andrews and R.A. Bergman, The Malta seawater RO facility, First World Congress on Desalination and Water Re-use, Florence, Italy, 1983.
- [5] T.J. Eckman, I. Moch and C.P. Shields, The TWIN™ Permeator — development and commercialization of a new RO device, Desalination, 96 (1994) 11–22.
- [6] H.W. Pohland, A.B. Hamida and K. Chida, Reliable supply of drinking water through use of high performance B-10 TWIN Permeators. A one year case history at Das Island, UAE, Desalination, 96 (1994) 303–310.
- [7] A.B. Hamida, M.H. Lutfi, A.A. Mongy and I. Ramadan, Advantages of higher conversion on Arabian Gulf, Al Zawrah SWRO plant, Proc. IDA World Congress on Desalination and Water Reuse, Madrid, 1997, 2 (1997) 341–349.
- [8] W.Ch. Barendsen and I. Moch, Design and operation of a 1.2 MGD (4542 CUMD) open sea intake plant in the Caribbean, Proc. IDA World Congress on Desalination and Water Reuse, Abu Dhabi, 1995, 3 (1995) 25–40.
- [9] I. Moch, Hollow fiber permeators and reverse osmosis, Desal. Water Reuse, 2/3 (1992) 30–37.
- [10] A. Gorenflo, J.A. Redondo and F. Reverberi, Basic options and two case studies for retrofitting hollow fiber elements by spiral-wound RO technology, Desalination, 178 (2005) 247–260.
- [11] F. Reverberi and A. Gorenflo, Three year operational experience of a spiral-wound SWRO system with a high fouling potential feed water, Desalination, 203 (2007) 100–106.
- [12] A. Gorenflo and P. Sehn, The 13,500 m³/d plant in Galilah (UAE): Experiences and performance within the first 12 months of operation, Deutsche Meerwasserentsalzung (DME) conference Seawater Desalination in United Arab Emirates, Berlin, 2006.
- [13] M. Busch and W.E. Mickols, Reducing energy consumption in seawater desalination, Desalination, 165 (2004) 299–312.

- [14] V. García-Molina, M. Busch and P. Sehn, Cost savings by novel seawater reverse osmosis elements and design concepts, *Desal. Wat. Treat.*, 7 (2009) 160–177.
- [15] A. Gorenflo, J.A. Redondo, M. Busch, A. Casañas and J. Johnson, Innovaciones tecnológicas en la osmosis inversa de agua de mar, IV Congreso nacional AEDyR, Desalación y Reutilización Mirando al Futuro, Las Palmas de Gran Canaria, 2003.
- [16] A. Casañas, M. Busch, M. Sanchez and R.S. Ramirez, Etapas de concentrador de salmuera de la Planta Desaladora del Sureste de Gran Canaria: primer año de funcionamiento, IV Congreso nacional AEDyR, Desalación y Reutilización Mirando al Futuro, Las Palmas de Gran Canaria, 2003.
- [17] M. Kurihara, H. Yamamura, T. Nakanishi and S. Jinno, Operation and reliability of very high-recovery seawater desalination technologies by brine conversion two-stage RO desalination system, *Desalination*, 138 (2001) 191–199.
- [18] V. Polasek, S. Talo and T. Sharip, Conversion from hollow fiber to spiral technology in large seawater RO systems - process design and economics, *Desalination*, 156 (2003) 239–247.
- [19] G.S. Nalle, Die head for extruding plastic netting and method of extruding such netting, US Patent 3067084, 1962.
- [20] J. Schwinge, D.E. Wiley and A.G. Fane, Novel spacer design improves observed flux, *J. Membr. Sci.*, 229 (2004) 53–61.
- [21] F. Li, W. Meindersma, A.B. de Haan and T. Reith, Novel spacers for mass transfer enhancement in membrane separations, *J. Membr. Sci.*, 253 (2005) 1–12.
- [22] G. Guillen and E.M.V. Hoek, Modeling the impacts of feed spacer geometry on reverse osmosis and nanofiltration processes, *Chem. Eng. J.*, 149 (2009) 221–231.
- [23] S.K. Karode and A. Kumar, Feed spacers for filtration membrane modules, US Patent 6989097, 2006.
- [24] J.S. Vrouwenvelder, D.A. Graf von der Schulenburg, J.C. Kruijthof, M.L. Johns and M.C.M. van Loosdrecht, Biofouling of spiral-wound nanofiltration and reverse osmosis membranes: A feed spacer problem, *Wat. Res.*, 43 (2009) 583–594.
- [25] P.R. Neal, H. Li, A.G. Fane and D.E. Wiley, The effect of filament orientation on critical flux and particle deposition in spacer-filled channels, *J. Membr. Sci.*, 214 (2003) 165–178.
- [26] C. Bartels, M. Hirose and H. Fujioka, Performance advancement in the spiral wound RO/NF element design, *Desalination*, 221 (2008) 207–214.
- [27] J.E. Johnson, Spiral wound element with improved feed spacer, US Patent 6881336, 2005.
- [28] M. Kihara, S. Minegishi and T. Nakanishi, Spiral reverse osmosis membrane element, reverse osmosis membrane module using it, device and method for reverse osmosis separation incorporating the module, US Patent 6656362, 2003.
- [29] H.-L. Yang, J.C.-T. Lin and C. Huang, Application of nanosilver surface modification to RO membrane and spacer for mitigating biofouling in seawater desalination, *Wat. Res.*, 43 (2009) 3777–3786.
- [30] R. Hausman, T. Gullinkala and I. Escobar, Development of low-biofouling polypropylene feedspacers for reverse osmosis, *J. Appl. Polym. Sci.*, 114 (2009) 3068–3073.
- [31] M. Saveliev, K. Carlson, S. Jersey, J. Burban, J. Shanahan, D. Averbeck, T. Adam and K. Peterson, Reverse osmosis system, US Patent 20090194478A1, 2009.
- [32] W.L. Bradford, R.E. Herrington and A.D. Clement, Filtration membrane and method of making same, US Patent 7311831, 2007.
- [33] F.P. Incropera and D.P. DeWitt, *Fundamentals of Heat and Mass Transfer*, John Wiley & Sons, New York, 1985.
- [34] G.E. Foreman and P.K. Worsley, Spiral wound membrane module for direct osmosis separations, US Patent 4033878, 1977.
- [35] The Dow Chemical Company, FILMTEC Membranes Product Information Catalog, Form 609-00204-1108, 2009.
- [36] M. Wilf, R. Franks, C. Bartels and N. Ikeyama, Device for measuring permeate flow and permeate conductivity of individual reverse osmosis membrane elements, US Patent 7584061B2, 2009.
- [37] S. Chikura and U. Yasuhiro, Seal ring holder for membrane element and membrane element, US Patent 20050057002A1, 2005.
- [38] W. Graham, A flow distributor plate for treatment of water by reverse osmosis, PCT Patent WO2009090510A1, 2009.
- [39] J.E. Johnson, M.J. Hallan, M.H. Peery and L.D. Johnson, Say good-bye to the weakest link: Introducing a new method for coupling membrane elements, Proc. 2003 Congress of the International Desalination Association, Paper BAH03-48, 2003.
- [40] W.A. Schwarz, Seal arrangement for rapid interconnection or axially arranged separation elements, US Patent 5851267, 1998.
- [41] D.M. Colby, F.K. Lesan, A.M. Franks, C.L. Hsieh and A.K. Mukherjee, Filtration element and method of constructing a filtration assembly, US Patent 7063789B2, 2006.
- [42] W.G.J. van der Meer, W.C. van Paassen and de P.J. Moel, Coupling unit for membrane elements, European Patent EPO925825B1, 2006.
- [43] E.M. Lohman, Operating report of the largest reverse osmosis desalting plant, *Desalination*, 96 (1994) 349–358.
- [44] T.I. Yun, C.J. Gabelich, B.M. Coffey and R.A. Bergman, Performance and economic evaluation of a 16-inch-diameter reverse osmosis membrane for surface water desalting, Proc. AWWA Membrane Conference, 2001.
- [45] C. Bartels, R. Bergman, M. Hallan, L. Henthorne, P. Knappe, J. Lozier, P. Metcalfe, M. Peery and I. Shelby, Industry consortium analysis of large reverse osmosis and nanofiltration element diameters, *Desalination and Water Purification Report No. 114*, US Bureau of Reclamation, 2004.
- [46] R.A. Bergman, J. Lozier, F. Wang and L. Henthorne, Large-diameter RO and NF membrane elements – commercialization and use update, Proc. AWWA 10th Biennial Membrane Technology Conference, Memphis, Tennessee, 2009.
- [47] M.J. Hallan, J.E. Johnson, M.S. Koreltz, M.H. Peery and G.W. Peterson, Design, development, and evaluation of sixteen inch diameter RO modules, Proc. IDA World Congress, Paper MP07-011, 2007.
- [48] M. Faigon and B. Liberman, Pressure center and boron removal in Ashkelon desalination plant, Proc. IDA World Congress, Paper BAH03-181, 2003.
- [49] T.I. Yun, C.J. Gabelich, M.R. Cox, A.A. Mofidi and R. Lesan, Reducing costs for large-scale desalting plants using large-diameter, reverse osmosis membranes, *Desalination*, 189 (2006) 141–154.
- [50] R.S. Ong, J.E. Johnson and E. Zhao, Sixteen-inch reverse osmosis module performance in water reuse, Proc. SIWW Water Convention 2009, Paper IWA 1098, 2009.
- [51] A. von Gottberg and R. Lesan, Meeting the challenges of construction, operation, and maintenance of large scale RO elements, Proc. AWWA Membrane Technology Conference, 2005.