

Pilot-scale O₃/BAC process for the advanced treatment of the Songhuajiang River, northeast China

Xiaodong Wang^{a,d,†}, Tingting Cao^{b,†}, Xindong Wei^c, Jinming Jiang^d, Chongwei Cui^b,
Weijun Gao^{a,d,*}

^aSMART, Qingdao University of Technology, Qingdao 266033, China, emails: gaoweijun@me.com (W.J. Gao),
jjmwwolf@outlook.com (J.M. Jiang)

^bState Key Laboratory of Urban Water Resources Centre, School of Environment, Harbin Institute of Technology, Harbin 150090,
China, emails: 15545009383@163.com (T.T. Cao), cuichongwei1991@126.com (C.W. Cui)

^cSchool of Environmental and Municipal Engineering, Jilin Jianzhu University, Changchun 130118, China,
email: xindong33@hotmail.com (X.D. Wei)

^dFaculty of Environmental Engineering, The University of Kitakyushu, Kitakyushu 808-0135, Japan, email:
369050446@qq.com (X.D. Wang)

Received 8 June 2020; Accepted 18 November 2020

ABSTRACT

To increase the safety of drinking water supply for residents, the O₃/BAC (ozonation and biological activated carbon filtration) advanced treatment was investigated through a pilot-scale water plant in Harbin City. Results indicated that the raw water of the Songhuajiang River contained a high content of turbidity, chemical oxygen demand (COD_{Mn}), and NH₃-N, which resulted in substandard water quality via the conventional treatment. However, after treatment by the O₃/BAC process, the average removal rates of turbidity, COD_{Mn}, NH₃-N, UV₂₅₄, total organic carbon, and trihalomethane formation potential in effluent were 97.97%, 84.84%, 64.29%, 87.39%, 72.09%, and 78.67%, respectively. The combined effect of the pre-ozonation and O₃/BAC process also eliminated the precursors of disinfection by-products from water. The results indicate that the O₃/BAC process is effective and promising to treat water from the Songhuajiang River. Moreover, the stable operation of the system confirmed that it can meet the effluent requirements of the “Standards for drinking water quality” (GB5749-2006), and also ensure minimal fluctuations in the treated water.

Keywords: Pilot-scale study; O₃/BAC process; Stabilized operation; Songhuajiang River

1. Introduction

The quality of drinking water is closely related to human health [1,2]. Since the Songhuajiang River nitrobenzene pollution event in 2005, the Mopanshan Reservoir has been chosen as the only source of drinking water for the main urban area of Harbin City [3]. However, with the progress and development of human society, many problems have emerged for the Mopanshan Reservoir, including long-distance water diversion, eutrophication trend of the water

quality, and a single main water source. These restraints significantly decrease the water supply safety in Harbin City and hinder the local economic growth and improvement of the investment environment. Thus, it is urgent to seek a new water source. This can not only help Harbin break the long-term restraint by the single water source of Mopanshan Reservoir for urban areas, but can also significantly improve the water supply safety.

The World Health Organization (WHO) asserts that 80% of human diseases are related to water pollution [4]. It is

* Corresponding author.

† These authors contributed equally to this work and considered as co-authors.

necessary to evaluate the water quality to ensure the safety of drinking water. Until now, numerous countries have issued corresponding drinking water standards [5–7]. The main water quality indexes of China, America, Japan, and the European Union are presented in Table 1. The standards of some relevant water quality indexes of China are more stringent than those of developed countries. In this study, the “Standards for drinking water quality” (GB5749-2006) of China was utilized to appraise the water quality of the Songhuajiang River after the treatment.

The integrated ozone-activated carbon process suggested by Rivas et al. [8], has gradually attracted the attention of researchers and achieved good results in the field of water supply and drainage engineering [9,10]. This process has been proved effective for the elimination of recalcitrant organic pollutants. Li et al. [11] applied an integrated ozonation and biological activated carbon filtration (O_3 /BAC) process to remove sulfonamides. The content of sulfonamides decreased by 45% to 92% after treatment. The results indicated that BAC filtration was capable of overcoming the problem of increased formation of disinfection by-products caused by ozonation. The excellent effect of the O_3 /BAC process was also demonstrated by Östman et al. [12], Vatankehah et al. [13], and Liu et al. [14].

To ensure the drinking water safety with the Songhuajiang River as the water source, a pilot-scale test based

on the O_3 /BAC process combined with pre-ozonation was implemented. The raw water quality was evaluated to identify the primary problems of the Songhuajiang River. Particular attention was paid to the removal efficiencies of chemical oxygen demand (COD_{Mn}), turbidity, NH_3-N , UV_{254} , total organic carbon (TOC), and trihalomethane formation potential (THMFP) in each treatment unit in the case of the O_3 /BAC process. The stable operation of the O_3 /BAC process was also analyzed to ensure the feasibility of the treatment process.

2. Material and methods

2.1. Pilot-scale process setup

The pilot-scale plant, using the Songhuajiang River as the source of water, was located at a water purification plant in Harbin City. The conventional treatment process used in this work consisted of coagulation, precipitation, filtration, and sterilization. To improve the effluent water quality, an advanced treatment- O_3 /BAC process was utilized, with a pre-ozonation tank added before the coagulation tank and the main ozonation treatment unit attached after the sand filtration tank. The BAC filtration unit was behind the main ozone contact tank. The schematic process is illustrated in Fig. 1. The pilot plant scale was 5.0 t/h. Among these

Table 1
Comparison of the partial water quality indexes of China, America, Japan and European Union

Index	Limiting value			
	China	America	Japan	European Union
pH	6.5–8.5	6.5–8.5	5.8–8.6	6.5–9.5
Chromaticity (PCU)	15	15	5	Acceptable and no odor
Turbidity (NTU)	1	N/A	1	Acceptable and no odor
COD_{Mn} (mg/L)	3	/	3 (1)	5
NH_3-N	0.5	/	/	/
Trichloromethane (mg/L)	0.06	/	/	/
Chloral	0.1	/	/	/

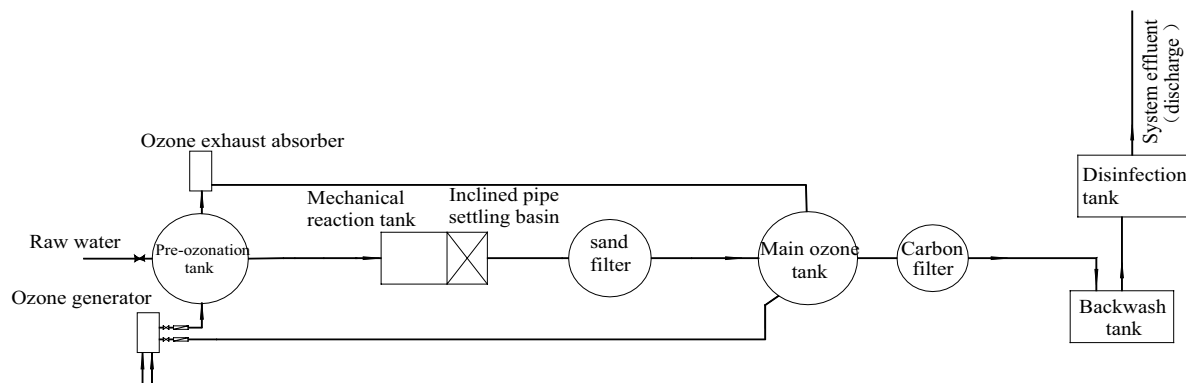

Fig. 1. Diagram of process flow.

processing units, composite aluminum ferric was used as a coagulant to strengthen the coagulation effect. The height, diameter, and valid volume of the two ozone contact tanks, which were made of stainless steel, were 2.5 m, 800 mm, and 2.0 m³, respectively. The hydraulic retention time of the pre-ozonation tank was 5 min, while it was 10 min for the main ozonation contact tank. For the two ozone schemes, the air was applied as the feed gas to produce ozone by an ozone generator (WH-H-Y3, Nanjing Wohuan Technology Co., China). Then, the ozone was bubbled into the contact tank by water ejector. The ozonation off-gas was recovered to increase the ozone absorption rate as well as the coagulation, reaction, and precipitation effect in the water.

Furthermore, the conventional filtration was based on quartz sand, while the BAC filtration mainly relied on the loaded microorganism, granular active carbon, and cobble. The washing scheme of the conventional filtration was 2 min of air washing, 3 min of air-water backwashing, and 5 min of water washing with a washing intensity of 12.5 L/(m² s). The backwashing intensity of the BAC filtration (height 3.3 m, ID 1 m), which applied the air-water backwashing technique, was set as 11.5 L/(m² s) for 10 min.

2.2. Conventional water quality parameters

The Songhuajiang River, located in Northeastern China, undergoes a long frozen period from December to April. The annual mean temperature is about 3°C. Water samples were collected in triplicate by Teflon bottles from the outlet of each treatment unit during a month in 2017. Then the collected samples were transferred to the laboratory and stored at -20°C until further analysis. The turbidity was determined by a turbidimeter (TL23, HACH, America). Chromaticity was measured by a colorimeter (XZ-BS, Shanghai, China). The pH value was determined by a portable pH meter (PHH-7200, OMEGA, America). Alkalinity was measured by the acid-base titration method. The COD_{Mn} was determined by the oxidation of potassium permanganate. The ammonia-nitrogen (NH₃-N) content was measured by the salicylic acid-hypochlorite photometric method. UV₂₅₄ usually represents the aromatic character of the organic matter, which was determined by the specific UV absorption at 254 nm (DR6000, HACH, America). The THMFP and disinfection by-products (DBPs) were determined by a gas chromatography (TRACE™ 1310, Thermo Scientific™, USA) equipped with an electron capture detector [15–17]. TOC was measured by the nondispersive infrared absorption method using a TOC analyzer (model-VCSH, Shimadzu, Japan).

3. Results and discussion

3.1. Raw water quality analysis of the Songhuajiang River

The relevant water quality parameters of the Songhuajiang River are listed in Table 2. The average contents of turbidity, COD_{Mn} and NH₃-N were 57 NTU, 5.85 mg/L, and 1.07 mg/L, respectively. These values exceed the threshold value of “Standards for drinking water quality” (GB5749-2006), which states that their maximum values should be 1 NTU, 3 mg/L, and 0.5 mg/L, respectively. Thus, attention was mainly paid to the monthly monitoring of these three parameters in this study, as depicted in Fig. 2. It is interesting to note that the turbidity value of the Songhuajiang River was extremely high from April to November, while it sharply reduced from December to March. The turbidity in spring and summer was on average five-fold higher than that in autumn and winter. This is because the precipitation is plentiful from April to November in Harbin City, resulting in an increase in surface runoff and floating granules. In contrast, the river enters a frozen period from December to April, which is the main reason for low turbidity. Furthermore, the relatively high turbidity can directly influence the subsequent disinfection effect and increase the use of disinfectants. It can even increase the content of DBPs in water and decrease effluent safety.

For COD_{Mn}, all the monitored values were over the standard value. Especially, the COD_{Mn} value reached a peak in May. This may be due to the surface runoff and sewage discharge from the circumjacent factories. However, the value for NH₃-N dramatically increased in the frozen period, which was primarily due to the following reasons: (1) the low precipitation resulting in the poor dilution capability for contaminants; (2) the high evaporation loss causing the high evaporated concentration of contaminants; (3) the low water temperature and dissolved oxygen leading to poor biological activity and purification ability; and (4) organic matter in the sediment reduced to NH₃-N and released into the water [18,19]. The high NH₃-N content can not only affect the subsequent disinfection effect and increase chlorine consumption but also generate mutagenic materials including chloramine (NH₂Cl). These matters can lead to the production of trihalomethanes (THMs) and other DBPs in disinfected water and further reduce drinking water safety [20,21]. Besides, the turbidity, COD_{Mn} and NH₃-N values in the effluent treated by the traditional water purification process were 1.25 NTU, 3.08 mg/L, and 0.82 mg/L, respectively. The effluent quality of the traditional water purification process did not meet the drinking water standard.

Table 2
Raw water quality of the Songhuajiang River

Parameter	Monitoring mean value	Standard deviation	Parameter	Monitoring mean value	Standard deviation
pH	7.54	0.1	NH ₃ -N, mg/L	1.07	0.058
Turbidity, NTU	57	5.14	Temperature, °C	20.8	2.31
COD _{Mn} , mg/L	5.85	0.36	Alkalinity, mg/L as CaCO ₃	65	16.7
UV ₂₅₄ , cm ⁻¹	0.13	0.011	Trihalomethane formation potential, µg/L	347	38.2

The UV absorbance at 254 nm (UV_{254}) is a useful indicator for the characteristics of dissolved organic matter [22]. As seen in Table 2, the UV_{254} value was 0.13 cm^{-1} . It indicated that the Songhuajiang River possessed a high quantity of organic matter, which was similar to that of COD_{Mn} . The content of THMFP in the raw water was also large with a value of $347\text{ }\mu\text{g/L}$, which can enhance the productivity of DBPs for the utilization of liquid chlorine disinfection in the pilot-scale plant [23].

According to the raw water-quality monitoring of the Songhuajiang River, the water quality problems of this water plant mainly occurred during the frozen period in winter. Moreover, the Songhuajiang River is difficult to be treated by the traditional water purification process. Thus, it is necessary to adopt an advanced treatment process to treat the Songhuajiang River and ensure drinking water quality.

3.2. Analysis of ozone dosage

Ozone dosage is an important parameter for the O_3 /BAC process. In this study, concentration variations of COD_{Mn} and NH_3-N in the pre-ozone tank and main ozone tank were detected by changing the ozone dosage, in order to determine the appropriate ozone dosage to oxidize organics and NH_3-N in water. Ozone dosage was chosen as 0, 0.3, 0.4, 0.45, 0.5, 0.6, 1.0, and 1.5 mg/L, respectively. The relationship between ozone dosage and average removal rate of COD_{Mn} and NH_3-N is shown in Fig. 3.

As presented in Fig. 3, the removal of COD_{Mn} and NH_3-N treated by ozonation both improved with the increase in ozone dosage. The average removal rate of COD_{Mn} in the main ozone contact tank was 69.57%, which was far higher than that in the pre-ozone contact tank (9.43%). A similar phenomenon was observed for NH_3-N . Furthermore, when the ozone dosage was more than 1.0 mg/L, the removal rates of COD_{Mn} and NH_3-N oxidized by the pre-ozone process reached 20% and 10% and remained unchanged. However, the removal rate of the two indexes oxidized by the main ozonation process exceeded 60% when the ozone

dosage was higher than 0.4 mg/L. Thus, the organics and NH_3-N were primarily eliminated in the main ozonation contact tank, while the pre-ozonation process played an important role in the coagulation-supporting effect. This is in agreement with the previous studies, which indicated the coagulation-supporting effect of ozone [24,25]. Based on the above consideration, the ozone dosages in the pre-ozonation tank and the main ozonation tank were chosen as 1.0 and 0.4 mg/L, respectively.

The residual ozone was determined as 0.127 mg/L after the pre-ozonation process, reaching 87.30% of the ozone utilizing ratio. However, the residual ozone was measured as 0.116 mg/L after the main ozonation process, which was 71.00% of the ozone utilizing ratio. Although the excellent removal rate occurred in the main ozonation contact tank, the pre-ozonation process was more preferable to the main ozonation process for the ozonation utilizing ratio under the optimal dosage.

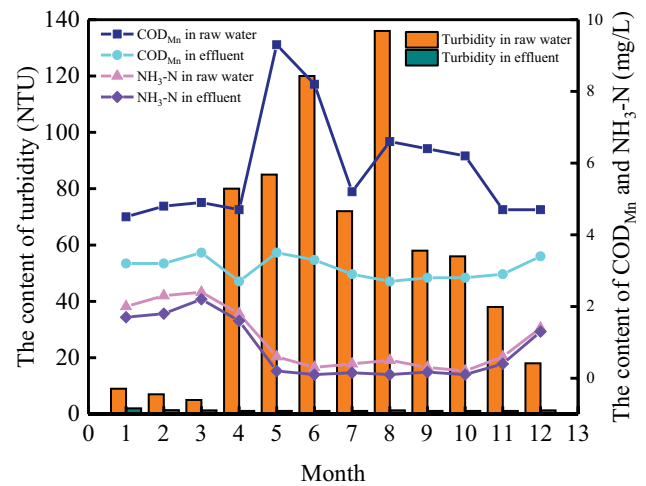

Fig. 2. Variation of turbidity, COD_{Mn} and NH_3-N in the raw water and effluent.

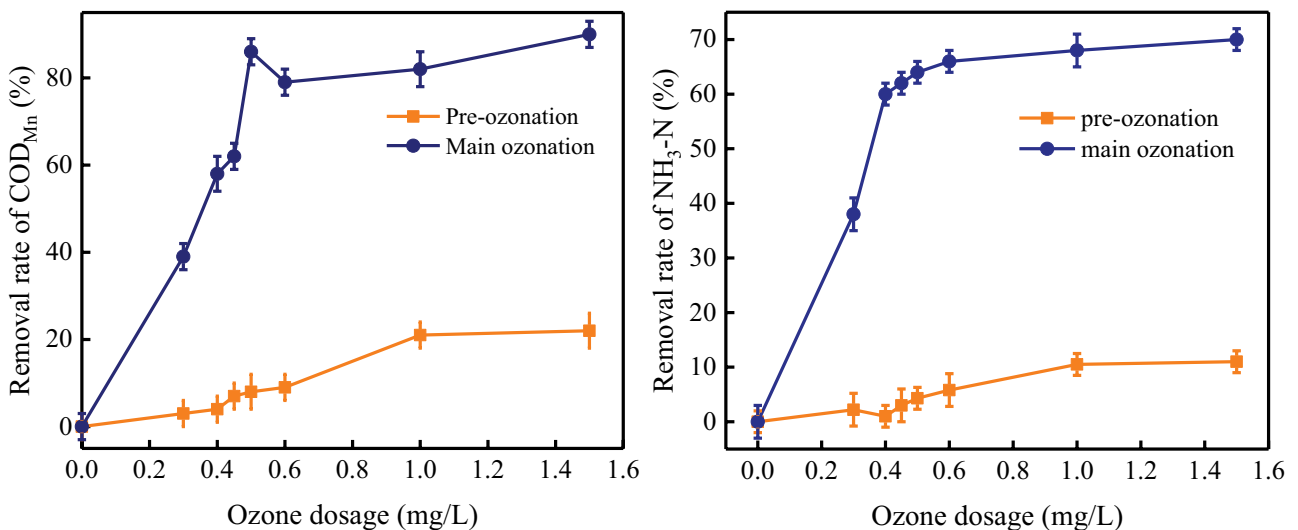

Fig. 3. Effect of ozone dosage on the removal of COD_{Mn} and NH_3-N .

3.3. Efficiency evaluation of each treatment process

3.3.1. Removal efficiency of turbidity

To evaluate the removal efficiency of the pre-ozonation and O₃/BAC processes in the cold period, turbidity, COD_{Mn}, NH₃-N, pH, and alkalinity were selected to represent the physical and organic characteristics of the treated water. The water quality after the pre-ozonation and O₃/BAC process is depicted in Fig. 4. The turbidity was reduced from 17.21 and 2.85 to 0.35 NTU, with a decrease of 83.44% after the pre-ozonation process and 87.72% after the O₃/BAC process. It indicated that the pre-ozonation process promoted the elimination of turbidity. This is perhaps because it can increase the contents of organic substances with oxygen-containing functional groups (e.g., carboxylic acid) in water to form polymers with hydrolysate of metal salts and calcium salts. These polymers can lower the electrostatic interaction of natural organic matter (NOM) on the inorganic particle surface and trigger the polymerization of dissolved organic substances to form poly-electrolytes. These substances can serve as adsorption bridge and destabilize high-stability algae and produce co-precipitation [26,27]. The further treatment of the O₃/BAC process resulted in the turbidity of treated water meeting the drinking water standard. Furthermore, compared with the raw water, the turbidity was completely removed with a value of 97.97%. This treatment not only reduced the suspended pollutants and the addition amount of coagulant but also increased the lifetime of the involved equipment.

3.3.2. Removal efficiency of COD_{Mn} and NH₃-N

COD_{Mn} usually represents the organic property of the studied water. As seen from Fig. 4, the value of COD_{Mn} in raw water was 6.4 mg/L, which was evidently over the drinking water standard (<3 mg/L). However, the COD_{Mn} reduced by 50.32% and 84.84% after the pre-ozonation and the O₃/BAC process, respectively. Therefore, it is evident that organic

matters are mainly degraded in the O₃/BAC process. The COD_{Mn} value reduced from 6.4 mg/L to 0.97 mg/L, indicating that COD_{Mn} of the treated water could meet the current drinking water standard. In the advanced treatment process, the oxidization of O₃ plays an important role, which can produce ozone and hydroxyl radical (*OH). These oxidants can quickly degrade organic matter and oxidize them into small molecules.

NH₃-N is another important parameter used to appraise the degree of water pollution, which is primarily derived from the discharge of domestic sewage, industrial effluents, and agricultural wastewater [28]. It is usually difficult to fully eliminate from the water and a high concentration of NH₃-N tends to cause eutrophication [29]. As seen from Fig. 4, the removal efficiencies of NH₃-N were 9.80% and 64.29% after the precipitation and O₃/BAC treatments, respectively. Compared with the O₃/BAC process, the treatment effect of NH₃-N in the pre-ozonation process was poor with a difference of 54.49%. NH₃-N was mainly removed in the O₃/BAC process. The content of NH₃-N in the effluent was 0.4 mg/L, which was less than the drinking water standard (<0.5 mg/L). Therefore, the Songhuajiang River water can reach the current drinking water standard through the upgraded treatment.

3.3.3. Removal efficiency of pH and alkalinity

Alkalinity and pH are also significant water quality parameters, which were monitored during the O₃/BAC treatment process. Fig. 4 shows the variation of alkalinity and pH in the raw water, pre-ozonation, and O₃/BAC units. Alkalinity and pH showed an evident downtrend after the pre-ozonation and O₃/BAC treatments. The pH value was reduced from 7.53 to 6.8, while the alkalinity value was reduced from 65 to 52. This is because some organic acids are generated for the O₃ oxidation, which causes a decrease in the pH value. However, the ozonation capacity, organic pollutant properties, and even microbial activity are all related to the variation of pH and alkalinity. Their low values are not beneficial for the O₃/BAC process. Accordingly, control of pH and alkalinity in the O₃/BAC process also plays an important role in removing pollutants.

3.3.4. Removal efficiency of UV₂₅₄, THMFP and TOC

For deep purification of drinking water, much attention has been given to the removal of natural organic matter such as macro-molecule humic acid and fulvic acid, which can easily react with active chlorine to generate halogenated carcinogens [30,31]. UV₂₅₄ can be used as an alternative parameter for some indexes, such as TOC, dissolved organic carbon, and precursor of THMs [32]. It is an important parameter to measure organic substances in water. The UV₂₅₄ variation in each treatment unit is shown in Fig. 5.

As depicted in Fig. 5, the average UV₂₅₄ value of raw water was 0.119 cm⁻¹. After the O₃/BAC process, the removal rate reached 87.39% with the UV₂₅₄ value decreasing to 0.015 cm⁻¹. The removal efficiency of UV₂₅₄ was 32.77% by the pre-ozonation process, 63.03% by the sand filtration process, and 87.39% by the O₃/BAC process. In contrast to the pre-ozonation process, the removal efficiency of the

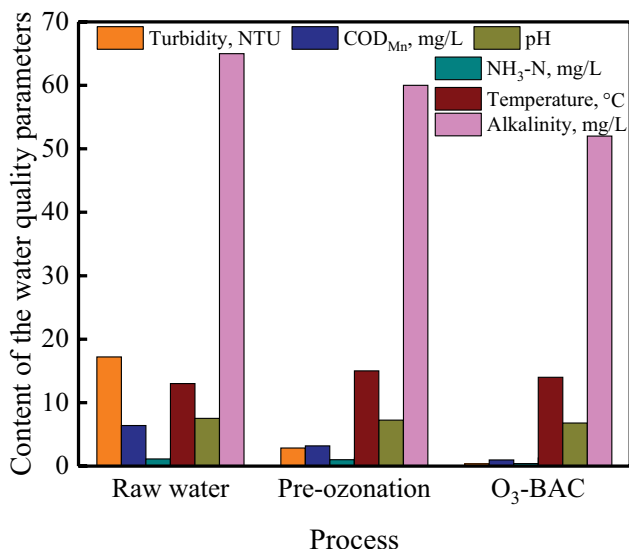

Fig. 4. Content variation of the water quality parameters treated with different units.-

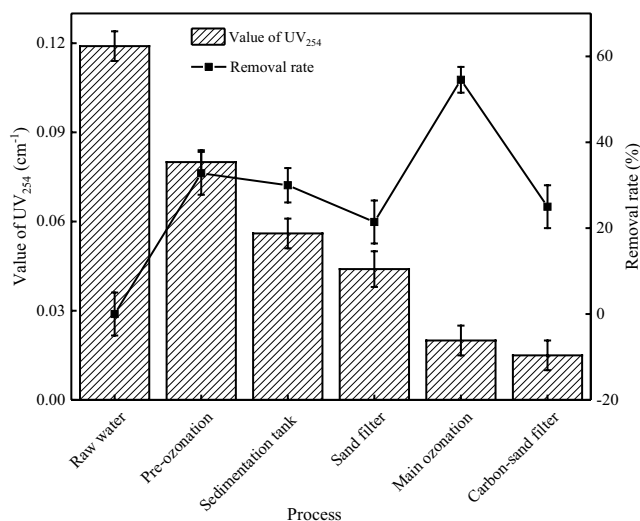

Fig. 5. Variation of effluent UV₂₅₄ in each process.

subsequent O₃/BAC process was higher than that of the pre-ozonation process with a difference of 54.62%. The UV₂₅₄ can be drastically eliminated by the O₃/BAC process. Since UV₂₅₄ represents organic substances with an aromatic ring structure or conjugated double bond, it can reflect the concentration of precursor of THMs. It is reported that ozone can easily react with C=C in organic substances [33]. It destroys the benzene ring and causes the aromatic property of organic matter to reduce or disappear. Therefore, the O₃/BAC process not only has high-efficiency for the removal of the trihalomethane precursor but also significantly reduces the content of organic matter in water.

DBPs have been a concern in the water supply and processing field. Especially, there is global concern regarding trihalomethane problems [34,35]. The components of NOM which can react with chlorine to generate THMs are identified as trihalomethane precursors. These precursors are usually determined by the THMFP to represent the content. The variation of THMFP in each treatment unit is shown in Fig. 6.

As illustrated in Fig. 6, the content of THMFP in raw water was 347 µg/L, which was eliminated by the pre-ozonation process with a removal rate of 38.9%. Although a part of THMFP can be removed by coagulation and precipitation, the elimination capacity is limited. For example, when the precipitation water passed through the filter tank, the concentration of THMFP increased with a removal rate of 36.6%. This may be attributed to the accumulation of algae and other organic matter in the filter material of the filter tank, since algae is also a kind of trihalomethane precursor [36,37]. Furthermore, the main ozonation process had a dominant removal effect on the THMFP. The removal rate reached 71.76% with the value reducing from 347 to 98 µg/L. However, the removal effect of activated carbon on the THMFP was also limited, because its removal by activated carbon mainly depends on its adsorption. The adsorption capacity of activated carbon decreases with long term use, resulting in poor removal efficiency. The THMFP showed an average decrease of 78.67% from raw water to the carbon-sand filter treated water. Thus, the trihalomethane

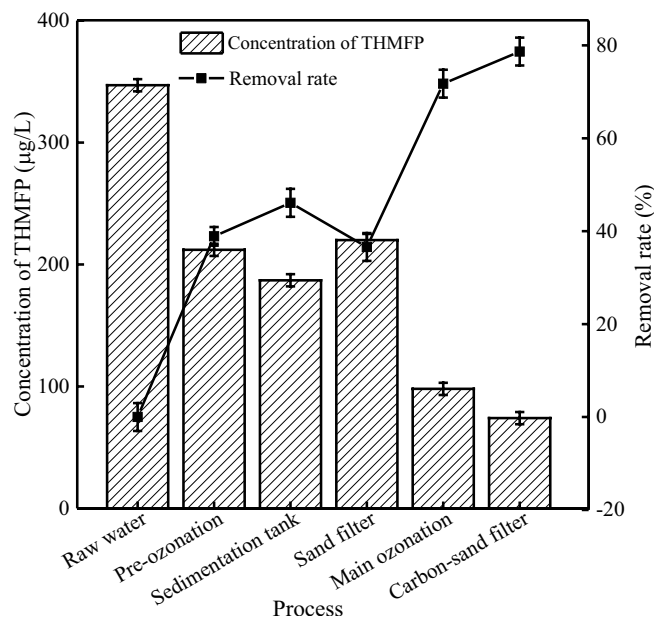

Fig. 6. Variation of THMFP in each treatment unit.

precursors in raw water can be effectively eliminated by the O₃/BAC process.

Furthermore, THMFP is also related to the variation of TOC after the ozonation oxidation. The change in TOC can reflect the state of THMFP to some extent since some dissolved organic matters are the primary components of the trihalomethane precursors. The content variation of TOC in each treatment unit is presented in Fig. 7. The elimination of TOC exhibited a steady increase with a removal rate of 18.6% after the pre-ozonation process and 72.09% after the O₃/BAC process. Moreover, the content of THMFP accounted for 8.07% of the TOC, while the proportion was reduced to 6.17%. This result indicated that a portion of trihalomethane precursors had indeed been eliminated from the water after the O₃/BAC process.

The detectable DBPs in the effluent are listed in Table 3. These detectable DBPs all reached the requirement of "Standards for drinking water quality" (GB5749-2006). Among them, the content of the high-profile trichloroacetic aldehyde was 0.004 mg/L, which reduced by 60% in comparison with the drinking water standard (0.01 mg/L). Moreover, the contents of common trichloromethane, trichloroacetic acid, and dichloroacetic acid also decreased by 91.67%, 93%, and 74%, respectively. The other DBPs, especially those containing bromine atoms generated by the ozonation oxidation, were all below the detection limit. The production of DBPs was under good control through the treatment of the O₃/BAC process. To sum up, the precursors of DBPs can be effectively eliminated by the O₃/BAC process in the Songhuajiang River water, and also the content of the DBPs meets the national drinking water standard.

3.4. Stable operation of O₃/BAC process

As mentioned above, the water quality deterioration of the Songhuajiang River usually occurred in the frozen period, increasing the treatment difficulty. The upgraded

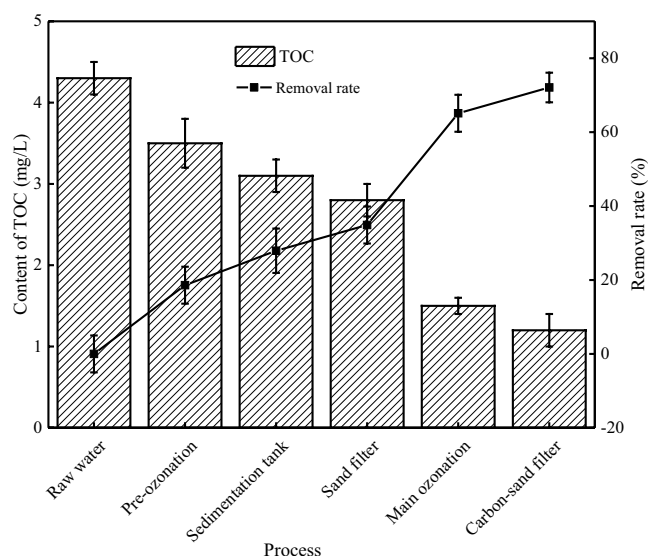

Fig. 7. Variation of TOC in each treatment unit.

O_3 /BAC process can significantly alleviate this problem. The turbidity, variation of the organic matter and even the content of trihalomethane precursors in the cold period can all be effectively removed through the upgraded O_3 /BAC process, and the effluent quality can meet the domestic drinking water standard. To evaluate the stable operation effect of the O_3 /BAC process, stable running of the pilot-scale test for about three months (October 2018–March 2019) was investigated during the frozen period of the water plant (Figs. 8–11). In this section, the parameters of turbidity, chromaticity, COD_{Mn} and NH_3-N were selected to appraise the water quality.

The turbidity variation during the stable operation is illustrated in Fig. 8. It can be seen from Fig. 8 that the turbidity of raw water and pre-ozonation effluent both fluctuated in waveform during the frozen period, while the effluent turbidity was stable after the subsequent treatments. In particular, the turbidity value remained unchanged for the carbon filter effluent. The removal rate of turbidity after the upgraded O_3 /BAC process was more than 95%. The effluent turbidity was about 0.2 NTU, indicating that the effluent met the threshold limit value (1 NTU) of “Standards for drinking water quality” (GB5749-2006).

Chromaticity is caused by the water-soluble humus, organic or inorganic substances, and reflects the apparent pollution status of water. The chromaticity variation during the stable operation is depicted in Fig. 9, which was evidently similar to the turbidity variation. The chromaticity was mainly removed in the sand filtration process and the O_3 /BAC process with a decrease of 71.05% and 93.16%, while the treatment efficiency of the pre-ozonation process was poor with a removal rate of only 7.89%. Chromaticity was primarily eliminated in the O_3 /BAC process. Moreover, the effluent chromaticity was stable, with an average value of 3 PCU during the operation of the system. This satisfactorily meets the threshold limit value (15) of “Standards for drinking water quality” (GB5749-2006).

The COD_{Mn} variation during stable operation is shown in Fig. 10. The change in COD_{Mn} was relatively stable during

Table 3
List of detectable DBPs in the effluent

Disinfection by-products	Structural formula	Content (mg/L)
Trichloromethane		0.005
Trichloroacetic aldehyde		0.004
Trichloroacetic acid		0.007
Dichloroacetic acid		0.013
Bromodichloromethane		<0.001
Dichloromethane		<0.0001
Tribromomethane		<0.001
Dibromochloromethane		<0.001
Cyanochloride		<0.01
2,4,6-Trichlorophenol		<0.001

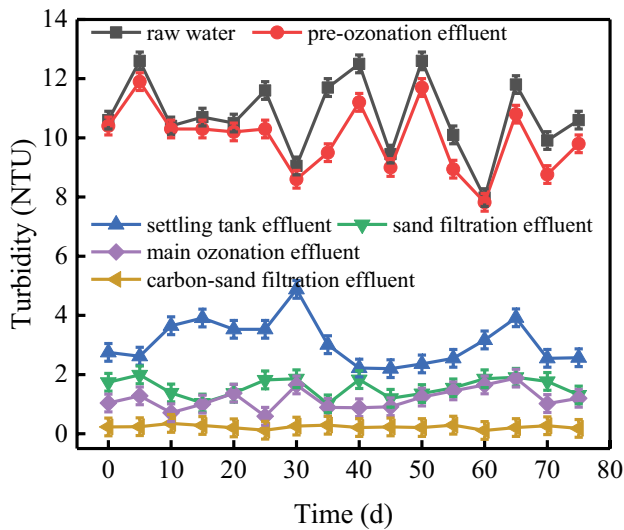

Fig. 8. Turbidity variation during stable operation.

Fig. 10. COD_{Mn} variation during stable operation.

Fig. 9. Chromaticity variation during stable operation.

Fig. 11. NH₃-N variation during stable operation.

the frozen period. The average concentration of COD_{Mn} in raw water was 5.71 mg/L, while the removal efficiency reached 4.03% after the pre-ozonation, 50.09% after the main ozonation, and 88.27% after the O₃/BAC process. Although the COD_{Mn} exhibited a large fluctuation at some point, the COD_{Mn} of the effluent remained stable. The average COD_{Mn} value was 0.67 mg/L in the effluent, which meets the threshold limit value (3 mg/L) of “Standards for drinking water quality” (GB5749-2006). In other words, the modified process has a good removal effect on the organic matter in water.

The NH₃-N variation during the stable operation is presented in Fig. 11. As seen from Fig. 11, the fluctuation of NH₃-N in each treatment unit was severe, especially in the initial stage of the system. The average concentration of NH₃-N was 1.58 mg/L in raw water. However, the value increased by 13.29% after the pre-ozonation process. This is because the organic nitrogen was oxidized

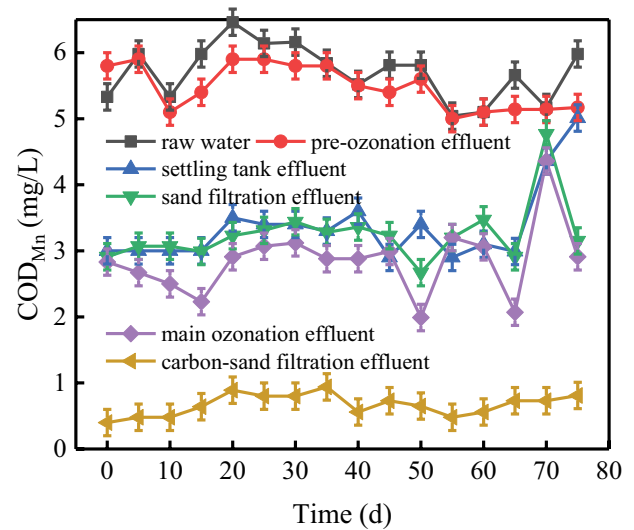
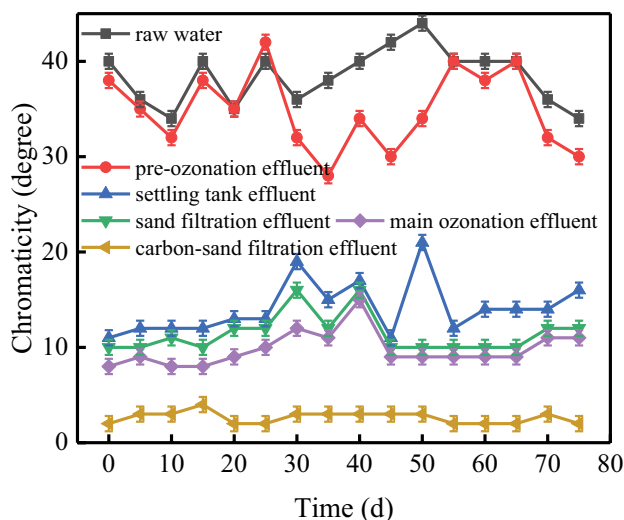
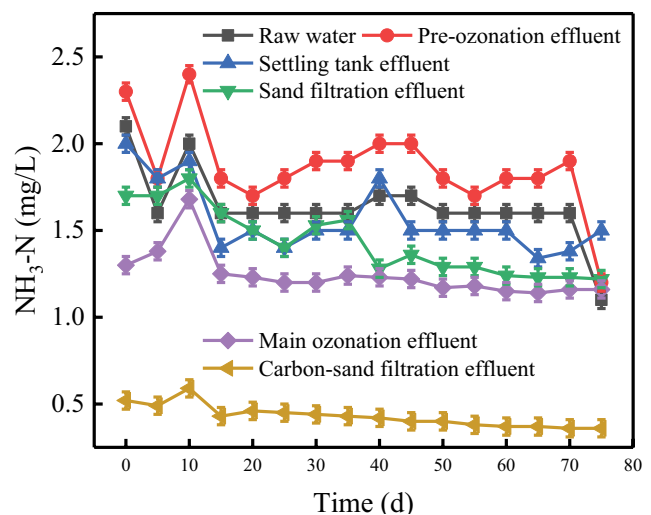
into NH₃-N via O₃, which further caused the increase in NH₃-N content after treatment by the pre-ozonation process. Through the subsequent O₃/BAC process, the NH₃-N content was drastically reduced by an average of 72.78%, especially by activated carbon filtration. This was mainly due to the combination of activated carbon adsorption and microbial degradation. Furthermore, the biological activated carbon column also had a strong impact load resistance for the NH₃-N removal, which was similar to the previous report [38]. As seen from Fig. 11, the variation of NH₃-N in the effluent was gentle with an average value of 0.43 mg/L, indicating that NH₃-N content was also in accordance with the threshold limit value (0.5 mg/L) “Standards for drinking water quality” (GB5749-2006).

In summary, the water quality of the Songhuajiang River can meet the current drinking water standard through the upgraded O₃/BAC treatment. The major water

quality indexes also showed no great fluctuations after the modified system ran stably for about three months.

4. Conclusions

In the pilot-scale study, the upgraded O₃/BAC process was utilized to evaluate the raw and treated water quality of the Songhuajiang River in a water plant in Harbin City. The results showed that the Songhuajiang River water exhibited a high content of turbidity, COD_{Mn} and NH₃-N, especially in the frozen period. This resulted in substandard water quality via conventional treatment. However, the O₃/BAC process was demonstrated as an appropriate technology for the removal of these pollutants from treated water. The optimal ozone dosage in pre-ozonation was 1.0 mg/L with ozonation utilizing ratio of 87.30%, while the optimal ozone dosage of the main ozonation was 0.4 mg/L with ozonation utilizing ratio of 71.00%. Moreover, the average removal rates of turbidity, COD_{Mn}, NH₃-N, UV₂₅₄, TOC and THMPF in the effluent after the O₃/BAC process were 97.97%, 84.84%, 64.29%, 87.39%, 72.09% and 78.67%, respectively. Importantly, the deuterogenic DBPs in the effluent were all under good control after treatment by the O₃/BAC process. These typical indexes in the effluent all reached the requirement of “Standards for drinking water quality” (GB5749-2006).

Furthermore, after the stable operation of the system for about three months, the whole treatment still maintained a good purification effect for the Songhuajiang River water. The effluent met the current drinking water standard. Moreover, the system showed no great fluctuations throughout the stable running period.

Acknowledgments

This article was not supported by any foundation. But the authors would like to thank the assistance of Prof. Chong-Wei Cui for the water quality data of Songhuajiang River. Xiao-dong Wang and Ting-ting Cao are the co-authors.

References

- [1] J.I. Price, M.T. Heberling, The effects of source water quality on drinking water treatment costs: a review and synthesis of empirical literature, *Ecol. Econ.*, 151 (2018) 195–209.
- [2] M. Sillanpää, M.C. Ncibi, A. Matilainen, Advanced oxidation processes for the removal of natural organic matter from drinking water sources: a comprehensive review, *J. Environ. Manage.*, 208 (2018) 56–76.
- [3] C. Wang, Y.J. Feng, S.S. Zhao, B.-L. Li, A dynamic contaminant fate model of organic compound: a case study of Nitrobenzene pollution in Songhua River, China, *Chemosphere*, 88 (2012) 69–76.
- [4] D.L. Cheng, H.H. Ngo, W.S. Guo, S.W. Chang, D.D. Nguyen, Y.W. Liu, Q. Wei, D. Wei, A critical review on antibiotics and hormones in swine wastewater: water pollution problems and control approaches, *J. Hazard. Mater.*, 387 (2020) 121682–121693.
- [5] J.H. Redmon, K.E. Levine, A.M. Aceituno, K. Litzenberger, J.M. Gibson, Lead in drinking water at North Carolina childcare centers: piloting a citizen science-based testing strategy, *Environ. Res.*, 183 (2020) 109126–109134.
- [6] X.W. Ding, Q. Zhu, A.F. Zhai, L. Liu, Water quality safety prediction model for drinking water source areas in Three Gorges Reservoir and its application, *Ecol. Indic.*, 101 (2019) 734–741.
- [7] A. Ikem, S. Odueyungbo, N.O. Egiebor, K. Nyavor, Chemical quality of bottled waters from three cities in eastern Alabama, *Sci. Total Environ.*, 285 (2002) 165–175.
- [8] F.J. Rivas, F. Beltrán, O. Gimeno, B. Acedo, F. Carvalho, Stabilized leachates: ozone-activated carbon treatment and kinetics, *Water Res.*, 37 (2003) 4823–4834.
- [9] T.F. de Oliveira, B. Cagnon, O. Chedeville, H. Fauduet, Removal of a mix of endocrine disruptors from different natural matrices by ozone/activated carbon coupling process, *Desal. Water Treat.*, 52 (2014) 4395–4403.
- [10] J. Zheng, T. Lin, W. Chen, H. Tao, Y.W. Tan, B.W. Ma, Removal of precursors of typical nitrogenous disinfection by-products in ozonation integrated with biological activated carbon (O₃/BAC), *Chemosphere*, 209 (2018) 68–77.
- [11] G. Li, W.W. Ben, H. Ye, D. Zhang, Z.M. Qiang, Performance of ozonation and biological activated carbon in eliminating sulfonamides and sulfonamide-resistant bacteria: a pilot-scale study, *Chem. Eng. J.*, 341 (2018) 327–334.
- [12] M. Östman, B. Björleinius, J. Fick, M. Tysklind, Effect of full-scale ozonation and pilot-scale granular activated carbon on the removal of biocides, antimycotics and antibiotics in a sewage treatment plant, *Sci. Total Environ.*, 649 (2019) 1117–1123.
- [13] H. Vatankhah, S.M. Riley, C. Murray, O. Quiñones, K.X. Steirer, E.R.V. Dickenson, C. Bellona, Simultaneous ozone and granular activated carbon for advanced treatment of micropollutants in municipal wastewater effluent, *Chemosphere*, 234 (2019) 845–854.
- [14] B. Liu, L. Gu, X. Yu, G.Z. Yu, C.M. Zhao, Q.F. Li, H. Zhai, Profile of dissolved organic nitrogen (DON) in full-scale ozone and biological activated carbon filter, *Desal. Water Treat.*, 55 (2015) 2069–2078.
- [15] W. Hou, S.H. Sun, M.Q. Wang, X. Li, N. Zhang, X.D. Xin, L. Sun, W. Li, R.B. Jia, Assessing water quality of five typical reservoirs in lower reaches of Yellow River, China: using a water quality index method, *Ecol. Indic.*, 61 (2016) 309–316.
- [16] J. Zhang, S.Y. Li, C.S. Jiang, Effects of land use on water quality in a River Basin (Daning) of the Three Gorges Reservoir Area, China: watershed versus riparian zone, *Ecol. Indic.*, 113 (2020) 106226–106236.
- [17] M. Varol, Spatio-temporal changes in surface water quality and sediment phosphorus content of a large reservoir in Turkey, *Environ. Pollut.*, 259 (2020) 113860–113868.
- [18] W.Q. Ding, W.B. Jin, S. Cao, X. Zhou, C.P. Wang, Q.J. Jiang, H. Huang, R.J. Tu, S.-F. Han, Q.L. Wang, Ozone disinfection of chlorine-resistant bacteria in drinking water, *Water Res.*, 160 (2019) 339–349.
- [19] D. Li, R.-H. Cao, H. Yang, Y.-J. Wang, S.-S. Lu, J. Zhang, Start-up and operation of biofilter coupled nitrification and canon for the removal of iron, manganese and ammonia nitrogen, *Environ. Sci.*, 39 (2018) 1264–1271.
- [20] F.Y. Li, J.Y. Wang, T.T. Cao, C.W. Cui, Spatial and seasonal variability of water quality in the Mopanshan Reservoir (Harbin, Northern China), *Water Sci. Technol. Water Supply*, 17 (2017) 389–398.
- [21] G.B. Ren, M.H. Zhou, Q.Z. Zhang, X. Xu, Y.C. Li, P. Su, A novel stacked flow-through electro-Fenton reactor as decentralized system for the simultaneous removal of pollutants (COD, NH₃-N and TP) and disinfection from domestic sewage containing chloride ions, *Chem. Eng. J.*, 387 (2020) 124037–124047.
- [22] S.Q. Zhou, Y.T. Wu, S.M. Zhu, J.L. Sun, L.J. Bu, D.D. Dionysiou, Nitrogen conversion from ammonia to trichloronitromethane: potential risk during UV/chlorine process, *Water Res.*, 172 (2020) 115508–115516.
- [23] J. Xu, Y.X. Zhao, B.Y. Gao, S.L. Han, Q. Zhao, X.L. Liu, The influence of algal organic matter produced by *Microcystis aeruginosa* on coagulation-ultrafiltration treatment of natural organic matter, *Chemosphere*, 196 (2018) 418–428.
- [24] K. Zhang, Z.-h. Zhang, H. Wang, X.-m. Wang, X.-h. Zhang, Y.F. Xie, Synergistic effects of combining ozonation, ceramic membrane filtration and biologically active carbon filtration for wastewater reclamation, *J. Hazard. Mater.*, 382 (2020) 121091–121100.

- [25] M. Sadrnourmohamadi, B. Gorczyca, Effects of ozone as a stand-alone and coagulation-aid treatment on the reduction of trihalomethanes precursors from water with high DOC and low calcium hardness, *Desal. Water Treat.*, 78 (2017) 117–126.
- [26] B. Liu, L. Gu, Q.F. Li, G.Z. Yu, C.M. Zhao, H.M. Zhai, Effect of pre-ozonation-enhanced coagulation on dissolved organic nitrogen in municipal wastewater treatment plant effluent, *Environ. Technol.*, 40 (2019) 2684–2694.
- [27] M. Ma, M. Wang, X.K. Cao, Y.X. Li, J.N. Gu, Yield of trihalomethane, haloacetic acid and chloral upon chlorinating algae after coagulation-filtration: is pre-oxidation necessarily negative for disinfection by-product control?, *J. Hazard. Mater.*, 364 (2019) 762–769.
- [28] W.L. Zhang, R. Fu, L. Wang, J.W. Zhu, J.T. Feng, W. Yan, Rapid removal of ammonia nitrogen in low-concentration from wastewater by amorphous sodium titanate nano-particles, *Sci. Total Environ.*, 668 (2019) 815–824.
- [29] S.M.A. Masoudi, A.H. Moghaddam, J. Sargolzaei, A. Darroudi, V. Zeynali, Investigation and optimization of the SND-SBR system for organic matter and ammonium nitrogen removal using the central composite design, *Environ. Prog. Sustainable Energy*, 37 (2018) 1638–1646.
- [30] D. Stefán, N. Erdélyi, B. Izsák, G. Zaráy, M. Vargha, Formation of chlorination by-products in drinking water treatment plants using breakpoint chlorination, *Microchem. J.*, 149 (2019) 104008–104015.
- [31] A. Matilainen, M. Sillanpää, Removal of natural organic matter from drinking water by advanced oxidation processes, *Chemosphere*, 80 (2010) 351–365.
- [32] N. Beauchamp, C. Bouchard, C. Dorea, M. Rodriguez, Ultra-violet absorbance monitoring for removal of DBP-precursor in waters with variable quality: enhanced coagulation revisited, *Sci. Total Environ.*, 717 (2020) 137225–137235.
- [33] M. Li, Z.Q. Chen, Z.Z. Wang, Q.X. Wen, Investigation on degradation behavior of dissolved effluent organic matter, organic micro-pollutants and bio-toxicity reduction from secondary effluent treated by ozonation, *Chemosphere*, 217 (2019) 223–231.
- [34] M. Diana, M. Felipe-Sotelo, T. Bond, Disinfection by-products potentially responsible for the association between chlorinated drinking water and bladder cancer: a review, *Water Res.*, 162 (2019) 492–504.
- [35] S.K. Golfinopoulos, A.D. Nikolaou, The screening of disinfection by-products in large and small water systems in Greece, *Desal. Water Treat.*, 58 (2017) 80–85.
- [36] M.U. Akcay, Z.Y. Avdan, H. Inan, Effect of biofiltration process on the control of THMs and HAAs in drinking water, *Desal. Water Treat.*, 57 (2016) 2546–2554.
- [37] A. Abdel-Karim, T. Gad-Allah, M.I. Badawy, A.S.G. Khalil, Removal of humic acid and chloroform from drinking water by using commercial nanofiltration and reverse osmosis membranes, *Desal. Water Treat.*, 59 (2017) 48–54.
- [38] J.-C. Lou, H.-Y. Chan, J.-Y. Han, C.-Y. Yang, High removal of haloacetic acids from treated drinking water using bio-activated carbon method, *Desal. Water Treat.*, 57 (2016) 25627–25638.