



Design of intelligent collection system for marine pollution information based on broadband Internet of Things

Xiaoyan Huang

Artificial Intelligence Institute, Chongqing Creation Vocational College, Chongqing 402160, China, email: huangxiaoyan2525@163.com

Received 4 June 2023; Accepted 15 August 2023

ABSTRACT

With the development and utilization of marine resources, marine pollution is becoming more and more serious, and has become an urgent problem to be solved. In order to obtain the situation of marine pollution in time and reduce its loss, this study designs a marine pollution information collection system based on the broadband Internet of things, and analyzes the components of the system. The experimental results show that the pH value of Class A sampling point is about 8 through the projection analysis of the clustering results in the characteristic space of environmental monitoring parameters; dissolved oxygen (DO) value is about 7. The salinity ranges from 25 to 35. The temperature is about 22°C. The pH value of Class B sample is about 8. DO value is between 3 and 5. The temperature is kept at about 22°C. The salinity ranges from 12 to 25. The pH value of type C sample is low. Its DO value is 3–5. The salinity is distributed between 6 and 19, and the temperature is maintained at about 23°C. The pH value of type D sample is between 8 and 12, with a wide range of changes and is alkaline. Compared with other three types of sample points, its salinity value is 0–15. DO value is the lowest, about 2. The temperature is maintained at about 24°C. The water quality at the sampling point of Class A data source is the best, and that of Classes C and D is the worst. To sum up, the system proposed in the study can be better applied to the actual judgment and monitoring of seawater pollution, and provide scientific data support for reducing marine pollution.

Keywords: Marine pollution; Internet of things; Cluster analysis; Monitoring

1. Introduction

The ocean is rich in resources and has great development potential. In order to maintain the sustained and rapid economic growth, countries all over the world are no longer satisfied with the development of land resources, and have turned their attention to the development of marine resources. In this process, the problem of marine environmental pollution is becoming more and more serious, the marine ecological environment is becoming worse and worse, and the marine natural disasters are more and more frequent. Natural disasters from the sea have caused great losses to human social life and life safety, and their threat is increasing day by day. How to control the marine

pollution has become a hot topic for many scholars. In order to alleviate the impact of freshwater resources and environmental degradation on human body and ecological environment, Zhai et al. [1] proposed a simple method to prepare multi-objective ultra-wetting porous materials. This material breaks through the limitation of single-size screening, and has universal effects on different types of pollutants through accurate wetting operation and fluid separation control. Mishra et al. [2] found that microfiber is a new type of pollutant widely distributed in the environment and has a very adverse ecological impact. In order to effectively control this marine pollutant, research is developing microfiber treatment technology. Jiang et al. [3] developed a targeted marine pollution control plan to achieve accurate identification of

marine pollution sources. The study uses the excitation–emission matrix analysis (EEMs) method of dissolved organic matter and the parallel factor analysis method of EMMs to determine the mixture of terrestrial humus, tryptophan and terrestrial and poplar humus and tyrosine components. The results verify the reliability of the model proposed in the study for DOM fingerprint identification of pollution sources in marine pollution areas, and provide a feasible method for pollution source identification in marine pollution events [4,5]. According to the above research, there is very little intelligent research on marine environmental monitoring. With the rapid development of social Internet of Things technology, scientific data and technical support are provided for the realization of intelligent marine environment monitoring, the comprehensive management of marine environment and the rational use of marine resources by China’s marine management departments. This study proposes to combine the Internet of things technology with marine pollution prevention and control, and on the basis of the Internet of Things technology, an intelligent system can be designed to monitor marine environmental pollution, thus making a certain contribution to reducing marine pollution [6,7].

2. Design of data acquisition subsystem of marine environment detection system

Data acquisition module is one of the important parts of marine environment monitoring system, which is mainly realized by wireless sensor network technology. Wireless sensor includes sensor nodes and sink nodes. Sensor nodes are mainly responsible for data acquisition, preprocessing and communication; sink node is responsible for initiating and maintaining network, collecting and uploading data.

The features of seawater must be taken into account while designing a sensor for the detection of marine environments. The sensor should generally exhibit low power consumption, impact resistance, and corrosion resistance. Sensor nodes allow for the connection of sensors. The connection of sensors can select a water and water combination to suit the requirements of each monitoring location [8,9]. The data can be communicated from the sensor node to the sink node, which can subsequently transmit it to the monitoring terminal and monitoring centre to complete the generation and acquisition of mediastinal data. Fig. 1 depicts the sensor node’s structural layout.

From the sensor node structure shown in Fig. 1, it can be seen that marine pollution detection is mainly realized

by pH meter. The parameters of each sensor used in this study.

Table 1 is the sensor parameter table. Through these sensors, the pH value, dissolved oxygen concentration, salinity, water temperature can be accurately measured. In order to make the marine environment detection system work for a long time without supervision, sensor network nodes need sufficient energy to support it. In order to achieve this goal, this study uses the dual power supply switching management, namely battery power supply and solar cell power supply. In the actual work process, the system is directly powered by the battery. When the battery power is insufficient, the solar panel will supplement the battery power to ensure the continuous and stable operation of the sensor network nodes.

Fig. 2 shows the workflow of sensor network nodes. (a) The main task of the sensor node is to send the collected data to the sink node. (b) It is the working flow diagram. The main work of it is to feedback the data information to acquisition node and send it to monitoring terminal.

3. Design of monitoring terminal for marine environment detection system

The monitoring terminal of marine environment monitoring system is mainly responsible for receiving, storing and sending data. As the core module of monitoring terminal, the main function of data acquisition is data storage and transmission control [10]. The wireless sensor at the front

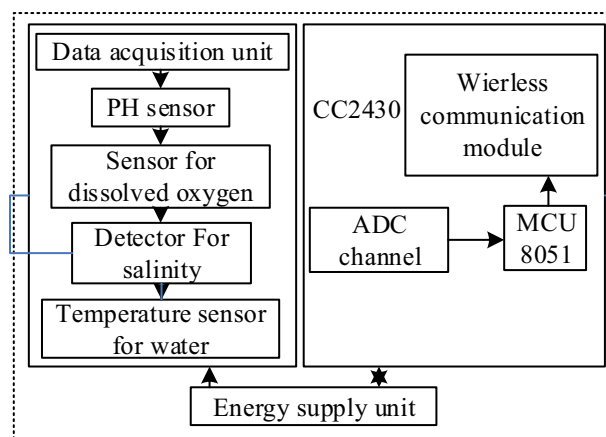

Fig. 1. Schematic diagram of sensor node structure.

Table 1
Node sensor parameter table

Sensor name	pH sensor	Dissolved oxygen sensor	Salinity sensor	Water temperature sensor
Product number	SensoLyt 700 IQ SW	FDO 700IQ SW	SAL-BTA	WQ101
Product brand	Germany WTW	Germany WTW	VERNIER	GWI
Measurement parameters	pH	Dissolved oxygen	Salinity	Water temperature
Accuracy and range	2–12 pH ≤0.02pH	0–20.00 mg/L ±0.02 mg/L	0–50,000 parts per million One (ppm) ±1% of full scale	±0.1°C –50°C~+50°C

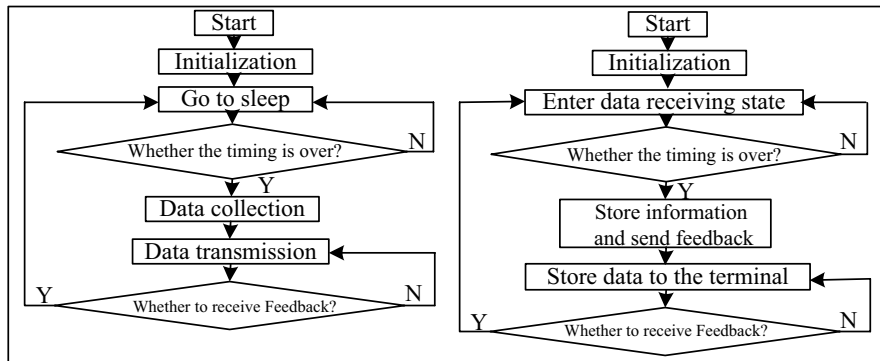

Fig. 2. Schematic diagram of the workflow of sensor network nodes.

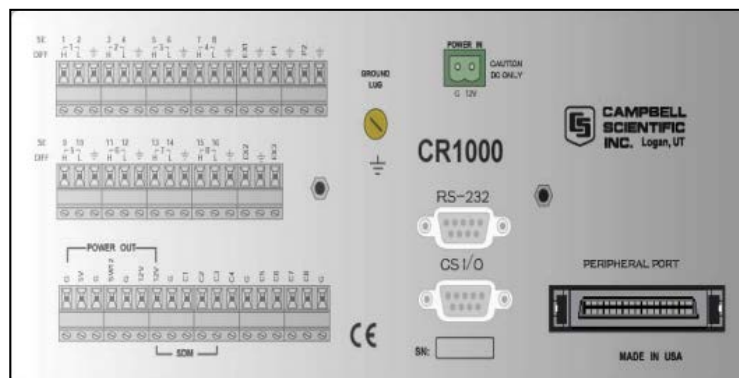

Fig. 3. Schematic diagram of CR1000 data collector.

end of the system sends the monitoring data of water quality (WQ) to the center through ZigBee technology, and then connects the ADCP with the data collector by Bluetooth module, and finally realizes the wired connection of each sensor through the serial port of the data collector. The schematic diagram of CR1000 data collector used in this study.

Through the data collector shown in Fig. 3, the monitoring terminal of the monitoring system can realize the control of receiving and sending data. In addition, the monitoring terminal can also collect data through the connection with each sensor. The sensors connected with the monitoring terminal include ADCP, CTD, wind speed and direction sensor and temperature and humidity sensor.

Fig. 4 shows the measurement process of analog sensor and the wiring method with data collector. (a) It is the measurement flow chart of analog sensor. It can be seen from the diagram that the sensor is used for data acquisition, and then the data collector is used for data processing. Finally, the processed data is sent to the computer for storage. (b–d) respectively, represent the single terminal connection method, differential connection method and pulse connection method of data collector and sensor.

4. Design of information management subsystem of marine environment detection system

In marine environment monitoring system, information management subsystem is mainly responsible for monitoring information management, information query and

information analysis. The system does data administration, WQ analysis, and GIS information processing based on the visualisation feature of the GIS. Spatial information analysis and graphic interactive presentation are both included in GIS information processing. For WQ classification, WQ analysis is based on the spatial vector genetic clustering analysis method [11,12].

Fig. 5 shows the spatial distribution of marine pH realized by GIS technology. In Fig. 5 different colors indicate different pH ranges, and GIS module can support the monitoring system in terms of pH value, salinity concentration and other information. Fig. 6 shows the effect of ocean wind and direction.

In the marine environment monitoring center, the scale of data transmission from sensors is very large, and it contains a large number of incomplete and fuzzy data. Therefore, it is necessary to further process the transmitted data. The marine environmental monitoring information management system designed in this study can extract valuable information from a large number of miscellaneous information through data mining technology. The fuzzy C-means (FCM) clustering algorithm and genetic algorithm are the system’s fundamental technologies.

FCM has good error convergence and local optimization ability. However, the global optimization ability of this algorithm is weak, and it is easy to fall into the local optimal situation. In this paper, the finite vector $X = \{X_k | X_k \in R^p, K = 1, 2, 3, \dots, n\}$ is divided into c classes, and the classification matrix U .

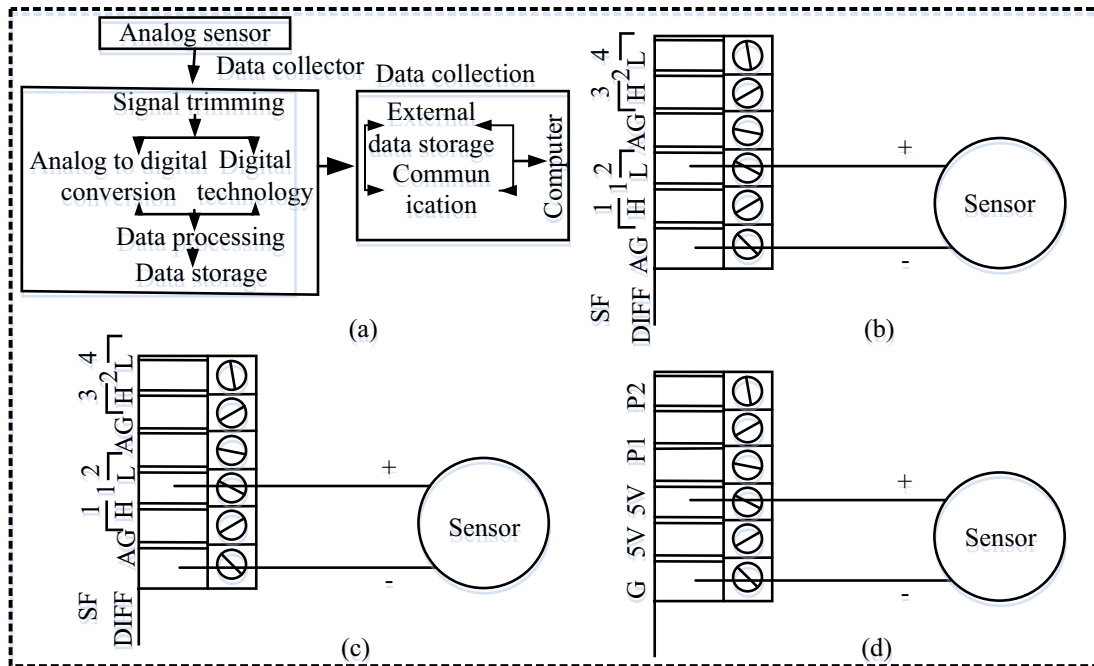

Fig. 4. Schematic diagram of analog sensor measurement process and connection method with data collector.

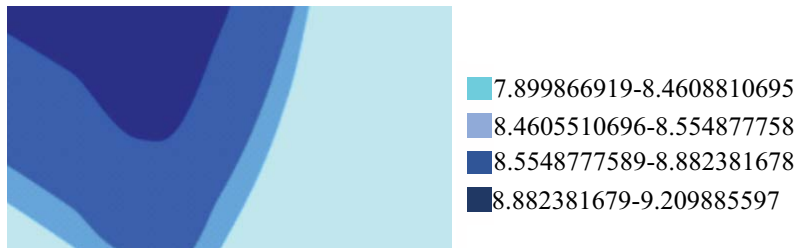

Fig. 5. Spatial distribution of pH.

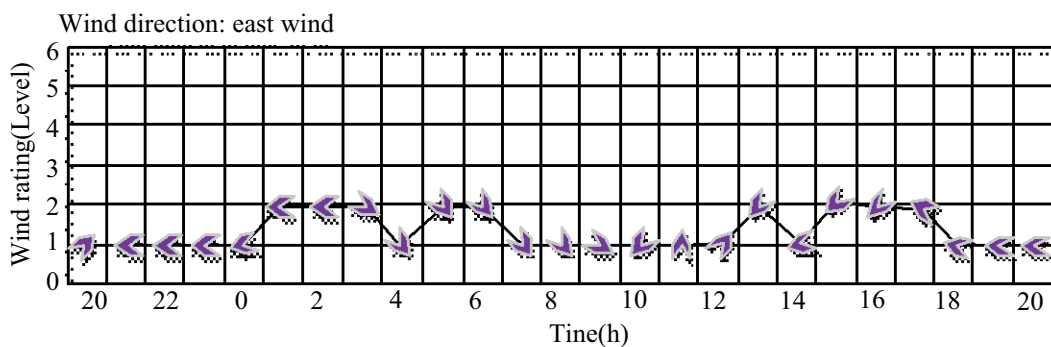

Fig. 6. Effect of wind direction.

$$U = \{U_{ik} | k = 1, 2, 3, \dots, n; i = 1, 2, \dots, c\} \quad (1)$$

where U_{ik} represents the membership degree of vector X_i in class c_k , and $0 \leq U_{ik} \leq 1$. The objective function is:

$$J(u, c) = \sum_{i=1}^c J_i = \sum_{i=1}^c \sum_{k=1}^n (u_{ik})^m d_{ik}^2 \quad (2)$$

where d_{ik} represents the spatial distance between vector X_k and class c_i and $c_i (1 \leq i \leq c)$, $c_i \in R^p$. In data processing, the genetic algorithm is used to confirm the cluster center, and then the fuzzy c -means clustering algorithm is used to divide the cluster. Next, the current cluster center is solved. Each time a new cluster center is obtained, a new cluster center is used to replace the previous one. In order to make the

monitoring of marine pollution more scientific and reasonable, this study inquired about China’s seaWQ standards, as shown in Table 2.

5. Experimental research and analysis of marine environment detection system

In order to verify the practicability of the marine environment monitoring system designed by this research, the corresponding experimental tests are carried out on the system, and the simulation is carried out with the test data. The results of data processing are demonstrated in a visual way, and then the system verification is completed. In this study, 30 sampling points are set up in a coastal area 200 m away from the bay. The distribution of sampling points is shown in Fig. 7.

A total of 300 groups of experimental data were obtained by continuous measurement of 30 sampling points set up in the study. Each point was sampled twice an hour for 5 h. The genetic initial population size n was set as 200, the maximum iteration times g was set as 60, the mutation probability P_m was 0.02, and the crossover probability P_c was 0.8. The data processing results are shown in Table 3.

Table 3 shows the data of sampling points processed by marine environmental monitoring system. It can be seen from Table 3 that 30 sampling points are divided into four categories by marine environmental monitoring system, of which class a sample points are the most and Class C sample points are the least. However, after the sample points are divided into four categories, the specific meaning of these four types of sample points is not known. In order to analyze the four types of sample points, the research shows

them in the feature space projection of marine environmental monitoring parameters.

Fig. 8 shows the projection result of clustering results in the characteristic space of environmental monitoring parameters. It can be seen from (a) and (b) that the pH value of Class A sample point is between 7 and 9, and most of them are around 8; the dissolved oxygen (DO) value is between 8 and 4, most of them are around 7; the salinity distribution is between 25 and 35, and basically concentrated in 30~35; the temperature is maintained at about 22°C. Therefore, it can be judged that the seaWQ in the corresponding area of such sample points is normal and not polluted. Similarly, the pH value of type B sample is between 7 and 9, and most of the sample points are around 8; the DO value is between 3 and 5; the temperature is maintained at about 22°C; the salinity distribution is between 12 and 25, which is far lower than that of type A sample. Compared with the seaWQ standard, it can be inferred that there is sewage discharge near the Class B sampling point, or there is a confluence of river water and sea water; the overall WQ is basically normal. It can be seen from (c) and (d) that the pH value of type C

Table 2
Sea WQ standards

Serial number	Project	First sort	Second category	Third category	Fourth category
1	pH		7.8-8.5		6.8-8.8
2	Dissolved oxygen	6	5	4	3
3	COD	2	3	4	5
4	Biochemical oxygen demand	1	3	4	5
5	Inorganic nitrogen	0.2	0.3	0.4	0.5

Table 3
Types of sampling points

Sample point	Sampling point
A	1, 2, 3, 4, 5, 6, 7, 8, 9, 10
B	11, 12, 13, 14, 15, 16, 17
C	18, 19, 20, 21, 22, 23
D	24, 25, 26, 27, 28, 29, 30

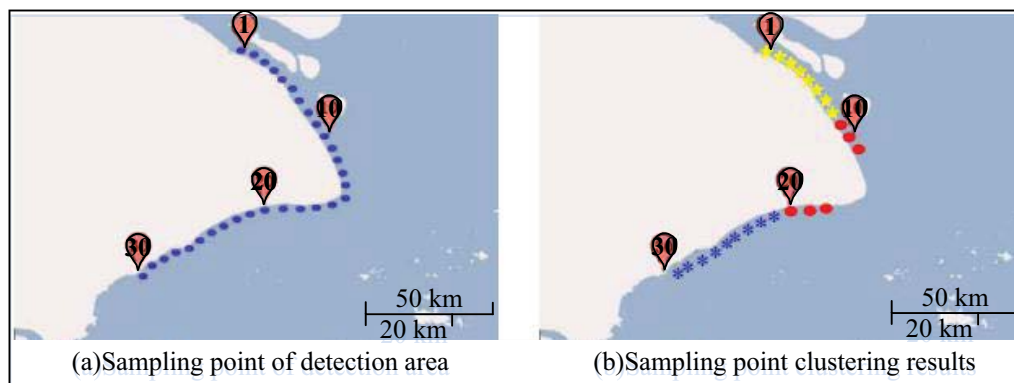

Fig. 7. Distribution of sampling points and clustering results of sampling points.

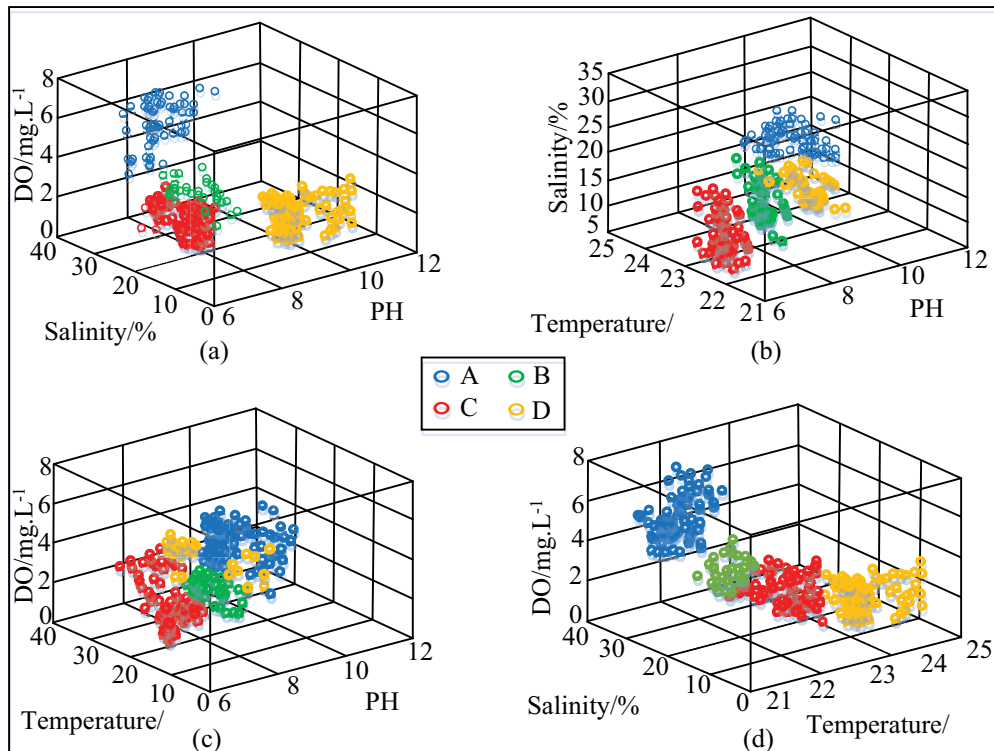

Fig. 8. Projection results of clustering results in the feature space of environmental monitoring parameters.

sample is low and weak acid; its DO value is similar to that of type B sample point, which is between 3 and 5; the salinity distribution is between 6 and 19, slightly lower than that of sample B; the temperature is maintained at about 23°C. The sea WQ of Class C sampling point is poor, so it is speculated that it is located near the sewage discharge outlet, so it is necessary to treat the regional seawater pollution prevention. It can be seen from (a) and (c) that the pH value of type D sample is between 8 and 12, with a wide range of variation and is alkaline; compared with the other three types of sample points, its salinity value is lower, distributed between 0 and 15; its DO value is the lowest, located at about 2; its temperature is maintained at about 24°C, which is the highest among the four types of sample points. The sea WQ of Class D sampling point is very poor and has been seriously polluted. Therefore, sewage treatment must be carried out in time. According to the above results, the sampling points of Class A data sources are located in the area with the best WQ, followed by Class B, and the sampling points of Classes C and D data sources are located in the area with poor WQ [13].

6. Conclusion

In recent years, with the frequent occurrence of marine natural disasters, marine pollution has gradually attracted the attention of people all over the world. This study studies the marine environment monitoring system from the aspects of data acquisition, monitoring terminal and information management, and verifies it by simulation. The results show

that the Internet of things monitoring system designed by this research can judge the WQ of various regions in the ocean through pH value, temperature, DO value and salinity. In the actual application results of the system, the pH value of Class A sampling points is between 7 and 9, most of which are around 8; DO values are between 8 and 4, most of which are around 7; The salinity ranges from 25 to 35; The temperature is maintained at about 22°C. The pH value of Class B sample is between 7 and 9, and most sample points are around 8; DO value is between 3 and 5; The temperature is kept at about 22°C; The salinity is between 12 and 25. The pH value of type C sample is low; Its DO value is between 3 and 5; The salinity is distributed between 6 and 19, and the temperature is maintained at about 23°C. The pH value of type D sample is between 8 and 12, with a wide range of changes and is alkaline; Compared with the other three types of sample points, its salinity value is relatively low, distributed between 0 and 15; DO value is the lowest, about 2; The temperature is maintained at about 24°C. To sum up, the system has excellent applicability and the result presentation is more intuitive. In addition, there are still some deficiencies in this study, that is, there are not many types of sensors in the system. It is hoped that more types of sensors will be added in the future research, so as to judge the seaWQ more accurately.

Fundings

The research is supported by: Chongqing Education Commission Science and Technology (No. KJQN202205404).

References

- [1] H. Zhai, R. Qu, X. Li, Y. Liu, S. Zhao, Y. Wei, L. Feng, A dually charged membrane for seawater utilization: combining marine pollution remediation and desalination by simultaneous removal of polluted dispersed oil, surfactants, and ions, *ACS Appl. Mater. Interfaces*, 13 (2021) 48171–48178.
- [2] S. Mishra, C.C. Rath, A.P. Das, Marine microfiber pollution: a review on present status and future challenges, *Mar. Pollut. Bull.*, 140 (2019) 188–197.
- [3] M. Jiang, Y. Sheng, C. Tian, C. Li, Q. Liu, Z. Li, Feasibility of source identification by DOM fingerprinting in marine pollution events, *Mar. Pollut. Bull.*, 173 (2021) 113060, doi: 10.1016/j.marpolbul.2021.113060.
- [4] M.A. Razzaque, M. Milojevic-Jevric, A. Palade, S. Clarke, Middleware for internet of things: a survey, *IEEE Internet Things J.*, 3 (2017) 70–95.
- [5] J. Lin, W. Yu, N. Zhang, X. Yang, H. Zhang, W. Zhao, A survey on internet of things: architecture, enabling technologies, security and privacy, and applications, *IEEE Internet Things J.*, 4 (2017) 1125–1142.
- [6] A.M. Rahmani, T.N. Gia, B. Negash, A. Anzanpour, I. Azimi, M. Jiang, P. Liljeberg, Exploiting smart e-health gateways at the edge of healthcare internet-of-things: a fog computing approach, *Future Gener. Comput. Syst.*, 78 (2018) 641–658.
- [7] B.L. Risteska Stojkoska, K.V. Trivodaliev, A review of internet of things for smart home: challenges and solutions, *J. Cleaner Prod.*, 140 (2017) 1454–1464.
- [8] I. Yaqoob, E. Ahmed, I.A.T. Hashem, A.I.A. Ahmed, A. Gani, M. Imran, M. Guizani, Internet of things architecture: recent advances, taxonomy, requirements, and open challenges, *IEEE Wireless Commun.*, 24 (2017) 10–16.
- [9] H.S. Dhillon, H. Huang, H. Viswanathan, Wide-area wireless communication challenges for the internet of things, *IEEE Commun. Mag.*, 55 (2017) 168–174.
- [10] S.E. Collier, The emerging enernet: convergence of the smart grid with the internet of things, *IEEE Ind. Appl. Mag.*, 23 (2017) 12–16.
- [11] Y. Mehmood, F. Ahmad, I. Yaqoob, A. Adnane, M. Imran, S. Guizani, Internet-of-things-based smart cities: recent advances and challenges, *IEEE Commun. Mag.*, 55 (2017) 16–24.
- [12] P.G. Benardos, G.C. Vosniakos, Internet of things and industrial applications for precision machining, *Solid State Phenomena*, 261 (2017) 440–447.
- [13] C. Perera, C.H. Liu, S. Jayawardena, M. Chen, A survey on internet of things from industrial market perspective, *IEEE Access*, 2 (2017) 1660–1679.